

# T-8722B

零件手册  
PARTS BOOK

双针直接驱动式大旋梭自动切线平缝机

TWIN NEEDLE DIRECT DRIVE LOCK STITCHER WITH LARGE HOOK  
AND THREAD TRIMMER

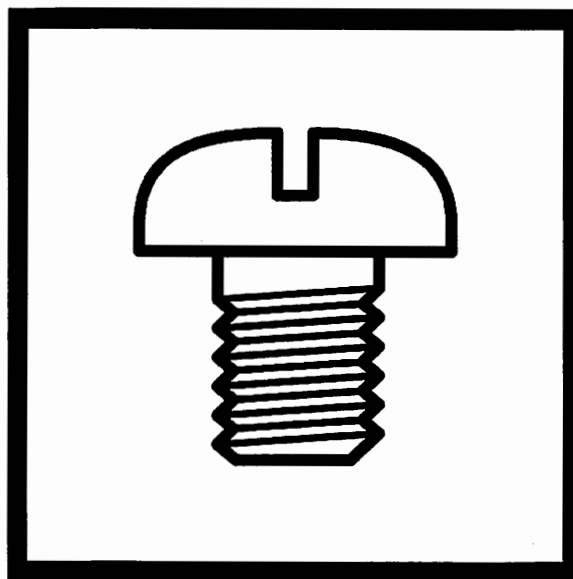

---

**brother®**

最新的零部件情报请参考(Parts Navigation)。  
The latest parts information, refer to the Parts Navigation.

<http://partsbook.brother.co.jp/partsnavi/chn/>  
<http://partsbook.brother.co.jp/partsnavi/eng/>

## 型号牌的读解法



## Description of model plate



3: Medium-weight materials

5: Heavy-weight materials

## 零件手册的使用说明

1. 本手册是根据截止至2006年11月的资料为基准而编制的。
2. 零部件设计若有变动，恕不另行通知。
3. 以组件为单位供应的零部件是用虚线框出。

## 目 录

A. 机体部分 .....	1
B. 上轴装置 .....	3
C. 针杆摆动装置 .....	5
D. 压脚装置 .....	7
E. 送布装置 .....	9
F. 倒缝装置 .....	11
G. 送布轴装置 .....	13
H. 定规部件 .....	15
J1. 旋梭装置 .....	17
J2. 旋梭装置 .....	21
K. 下轴装置 .....	23
L. 供油润滑装置 .....	25
M. 穿线装置 .....	29
N. 卷线装置 .....	31
P. 切线装置 .....	33
Q. 松线装置 .....	35
R. 扫线装置 .....	37
S1. 控制箱和马达装置 .....	39
S2. 控制箱装置 .....	41
T. 倒缝开关装置 .....	43
U. 电气部品装置 .....	45
V. 电磁抬压脚组件装置(选购件) .....	47
Z1. 附件 .....	49
Z2. 附件 .....	51
Wa. 警告标签 .....	53
Sp. 不同规格零部件一览表 .....	54
Ga. 工模具一览表 .....	55
索引 .....	57

## Notes for using this parts book

1. This book was prepared based on information available in November 2006.
2. Parts are subject to changes in design without prior notice.
3. Parts supplied as complete assemblies are circled by a dotted line.

## CONTENTS

A. Machine body .....	1
B. Upper shaft mechanism .....	3
C. Needle bar rocking mechanism .....	5
D. Presser foot mechanism .....	7
E. Feed mechanism .....	9
F. Quick reverse mechanism .....	11
G. Feed shaft mechanism .....	13
H. Gauge parts .....	15
J1. Rotary hook mechanism .....	17
J2. Rotary hook mechanism .....	21
K. Lower shaft mechanism .....	23
L. Lubrication .....	25
M. Threading mechanism .....	29
N. Bobbin winder mechanism .....	31
P. Thread trimmer mechanism .....	33
Q. Tension release mechanism .....	35
R. Thread wiper mechanism .....	37
S1. Control box and motor mechanism .....	39
S2. Control box mechanism .....	41
T. Quick reverse switch mechanism .....	43
U. Power supply equipment mechanism .....	45
V. Presser foot lifting solenoid set mechanism (Option parts) .....	47
Z1. Accessories .....	49
Z2. Accessories .....	51
Wa. Warning labels .....	53
Sp. Different parts list .....	54
Ga. Gauge parts list .....	55
Index .....	57

A. 机体部分 / Machine body

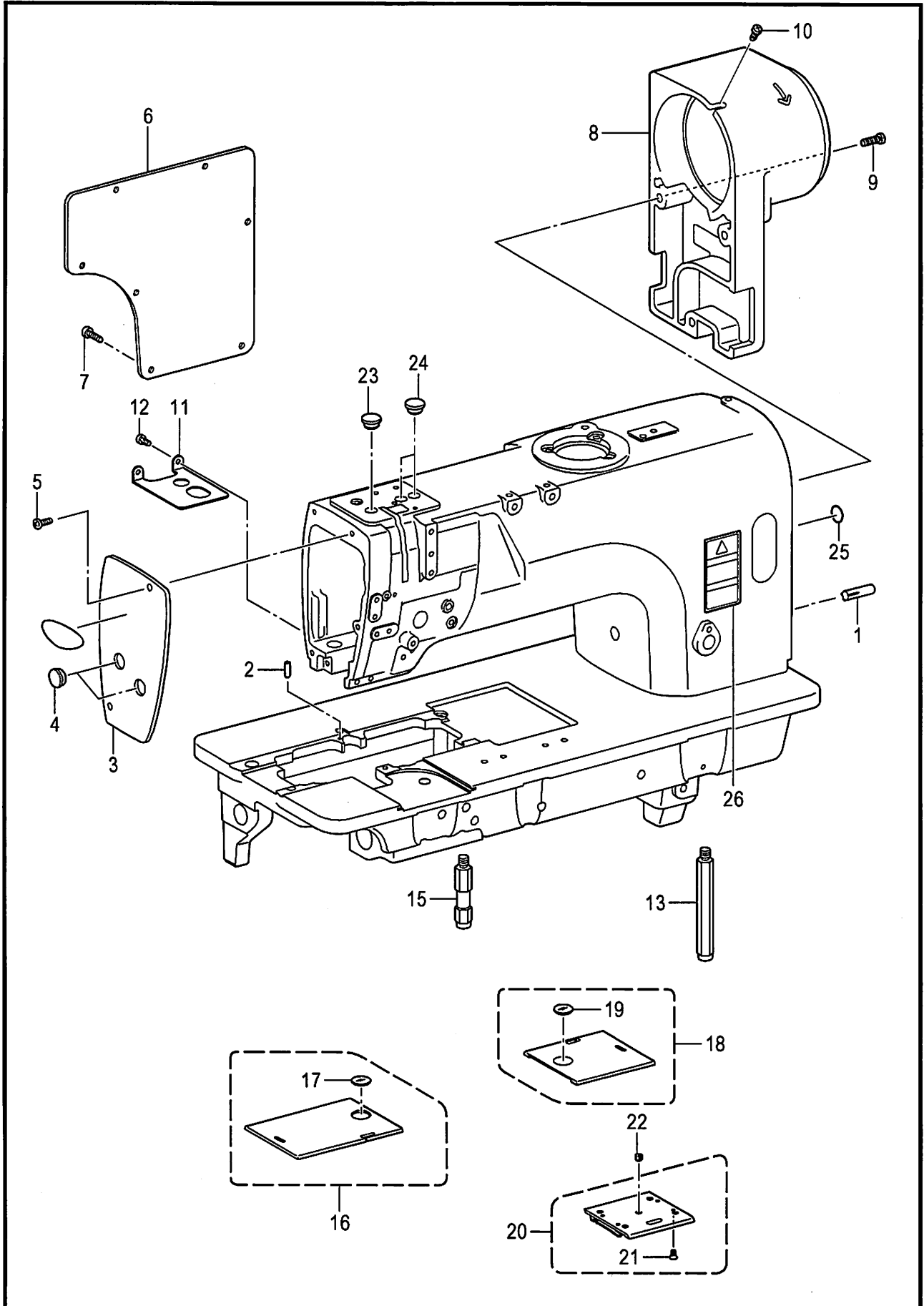

T-8722B-050

A. 机体部分 / Machine body

参照号	零部件序号	数量	零部件名称	NAME OF PARTS	RM
1	140063001	2	带槽销	DOWEL PIN	
2	SA3924001	1	定位销	POSITIONING PIN	
3	SA2440001	1	主板	FACE PLATE	
4	SA2929001	2	橡皮塞 12.5	RUBBER CAP, 12.5	
5	062500816	2	螺钉 M5X8	SCREW PAN M5X8	
6	SA2441001	1	侧板	REAR COVER	
7	062501216	7	螺钉 M5X12	SCREW PAN M5X12	
8	SA2442101	1	马达盖	MOTOR COVER	
9	062501416	3	螺钉 M5X14	SCREW PAN M5X14	
10	062501016	1	螺钉 M5X10	SCREW PAN M5X10	
11	SA2443101	1	防尘板	DUST PROTECTOR	
12	062500616	2	螺钉 M5X6	SCREW PAN M5X6	
13	SA2444101	1	脚柱 L	BED LEG L	
15	SA2445101	1	脚柱 S	BED LEG S	
16	SA2447001	1	推板LA组件	SLIDE PLATE, LA ASSY	
17	SA2479001	1	推板窗	BOBBIN WINDOW	
18	SA2449001	1	推板R组件	SLIDE PLATE ASSY, R	
19	SA2479001	1	推板窗	BOBBIN WINDOW	
20	S36663051	1	前推板组件	SLIDE PLATE F ASSY	
21	S34438051	4	螺钉 SM3.18-40X4	SCREW, FLAT SM3.18-40X4	
22	116010001	1	螺钉 SM5.16-40X4	SET SCREW, SM5.16-40X4	
23	SA2929001	1	橡皮塞 12.5	RUBBER CAP, 12.5	
24	SA2929001	2	橡皮塞 12.5	RUBBER CAP, 12.5	
25	S37060001	1	接地标记	LABEL, GROUNDING	
			<用于中国以外>	<Except for China>	
26	SA2040001	1	操作注意标签(日 / 英)	LABEL, CAUTION JPN/ENG	
			<用于中国>	<For China only>	
26	SA2041001	1	操作注意标签(中 / 英)	LABEL, CAUTION CHN/ENG	

T-8722B-050

B. 上轴装置 / Upper shaft mechanism

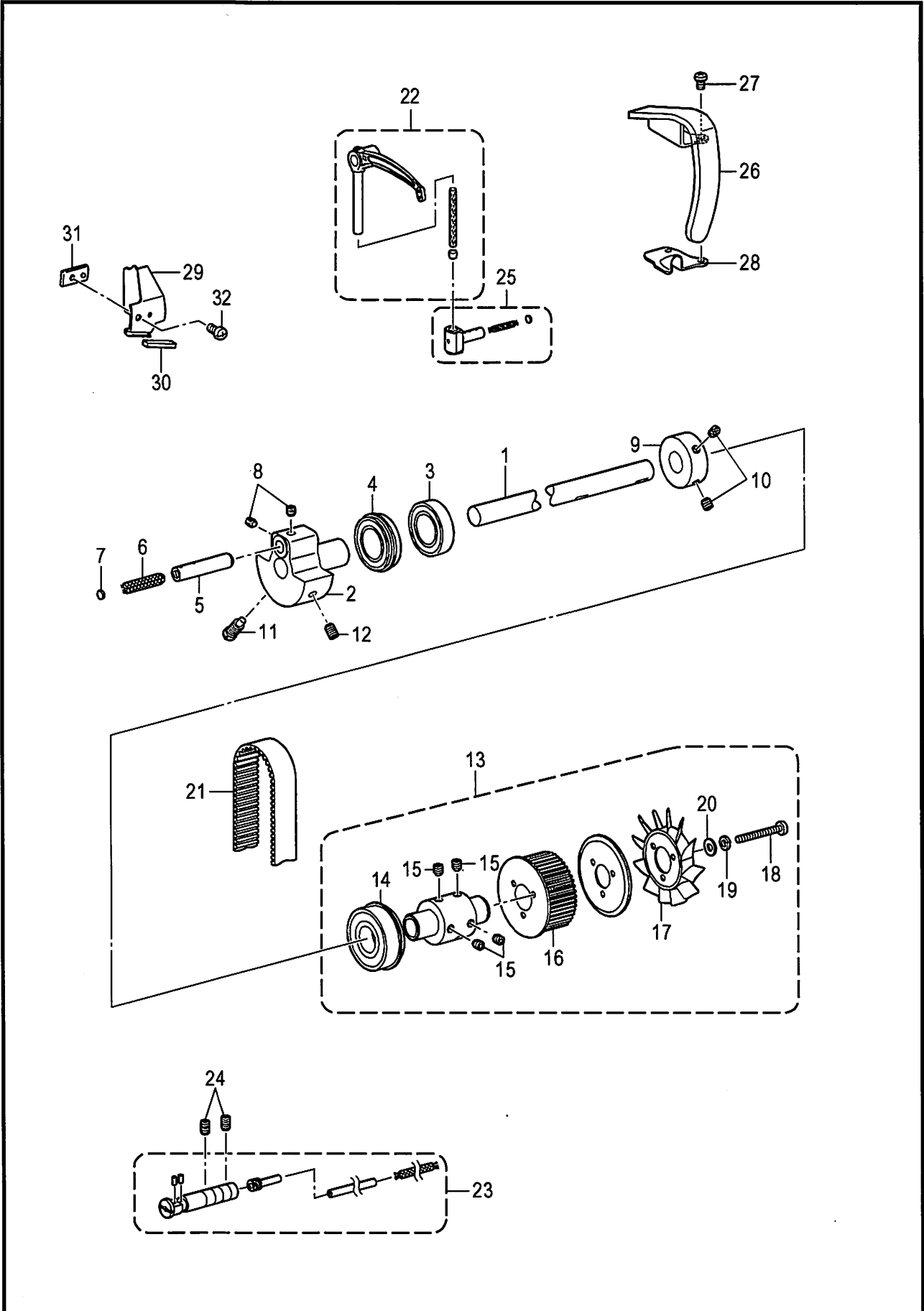

T-8722B-109



B. 上轴装置 / Upper shaft mechanism

参照号	零部件序号	数量	零部件名称	NAME OF PARTS	RM
1	SA2452101	1	上轴 DD	UPPER SHAFT, DD	
2	SA4089001	1	挑线杆曲柄	THREAD TAKE-UP CRANK	
3	S25234001	1	球轴承 6004ZZ	BALL BEARING, 6004ZZ	
4	S38707001	1	球轴承 6004ZZNR	BALL BEARING, 6004ZZNR	
5	SA6166001	1	针杆曲柄轴	CRANKSHAFT	
6	117006001	1	油线 L=60	WICK, L=60	
7	113014000	1	油线盖	PUSHER	
8	S25260001	2	固定螺钉 M6X5	SET SCREW SOCKET (FT) M6X5	
9	SA1120001	1	卷线驱动轮	BOBBIN WINDER DRIVING WHEEL	
10	S23651001	2	固定螺钉 M6X6	SET SCREW SOCKET (FT) M6X6	
11	S25235001	1	螺钉 M8	SCREW M8	
12	S25236001	1	螺钉 M6X10	SET SCREW SOCKET (FT) M6X10	
13	SA2460001	1	接头复合件	PRESSER ADJUSTING UNIT	
14	S38710001	1	球轴承 6204ZZNR	BALL BEARING, 6204ZZNR	
15	S23651001	4	固定螺钉 M6X6	SET SCREW, SOCKET (FT) M6X6	
16	SA2461001	1	同步轮 U DD	TIMING PULLEY, U DD	
17	S38713100	1	叶轮	FAN	
18	062403512	3	螺钉 M4X35	SCREW PAN M4X35	
19	028040242	3	弹簧垫圈 2-4	WASHER SPRING 2-4	
20	025040232	3	平垫圈 M4	WASHER PLAIN M 4	
21	SA2463001	1	同步皮带	TIMING BELT	
22	SA2937101	1	挑线杆组件 L2-L	THREAD TAKE-UP LEVER ASSY, L2-L	
23	SA2861101	1	挑线杆支撑轴总组件	THREAD TAKE-UP S-SHAFT UNIT	
24	012061036	2	螺钉 M6X10	SET SCREW SOCKET (FT) M6X10	
25	S13160001	1	挑线杆接头滑块组件 2	T-TAKE-UP SLIDE BLOCK ASSY, 2	
26	SA2469001	1	挑线杆防护罩	THREAD TAKE-UP LEVER COVER	
27	062500816	2	螺钉 M5X8	SCREW PAN M5X8	
28	SA4537001	1	防尘盖	DUST COVER	
29	SA3058101	1	遮掩板	SHELTER PLATE	
30	SA3065001	1	油毡	FELT	
31	SA3059101	1	遮掩板支座	HOLDER, SHELTER PLATE	
32	062500816	1	螺钉 M5X8	SCREW PAN M5X8	

C. 针杆摆动装置 / Needle bar rocking mechanism

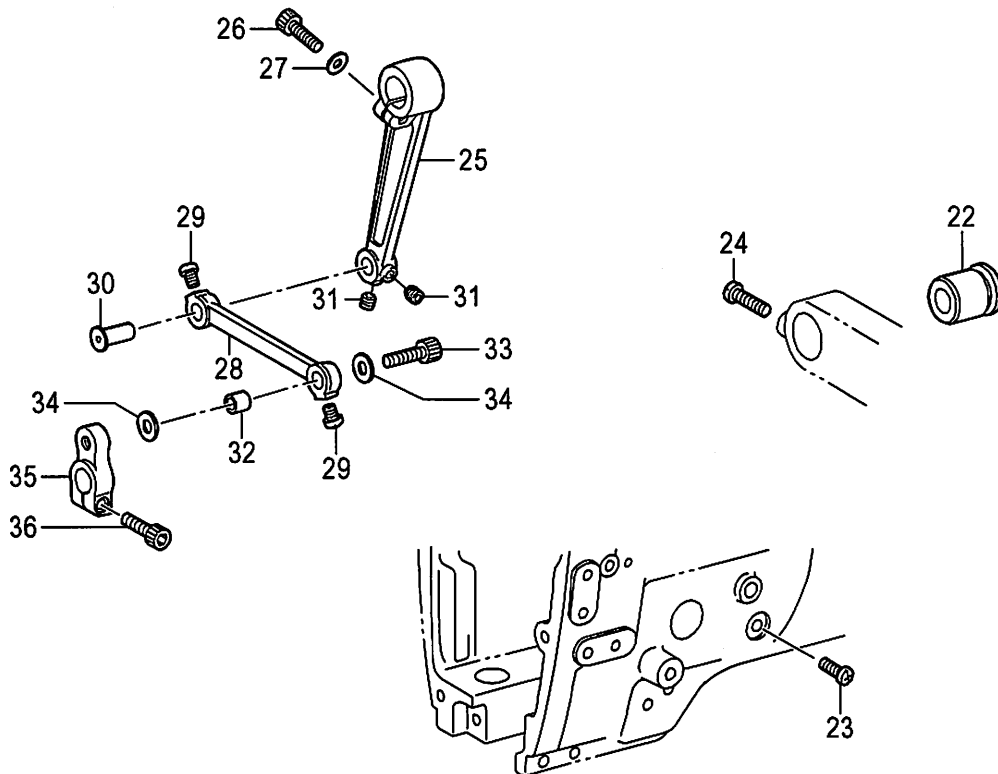
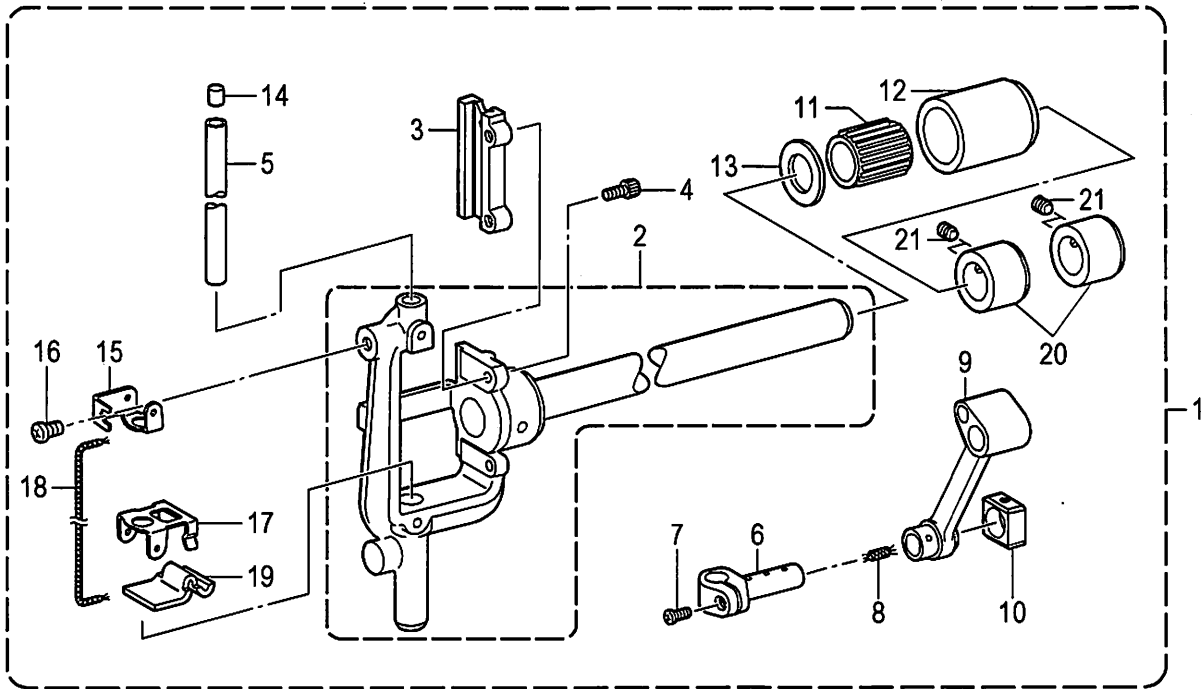

C . 针杆摆动装置 / Needle bar rocking mechanism

参照号	零部件序号	数量	零部件名称	NAME OF PARTS	RM
1	SA4124301	1	针杆摆动轴组件	NEEDLE BAR ROCKER SHAFT ASSY	
2	SA3854001	1	针杆台组件	NEEDLE BAR BASE ASSY	
3	SA2474201	1	角滑块槽	SLIDE BLOCK SLIDER	
4	018401036	2	螺栓 M4X10	BOLT SOCKET M4X10	
5	SA2475101	1	针杆	NEEDLE BAR	
6	SA3710001	1	针杆抱箍	NEEDLE BAR CLAMP	
7	062350816	1	螺钉 M3.5X8	SCREW PAN M3.5X8	
8	112728001	1	油线 L=50	WICK, L=50	
9	SA3711101	1	针杆曲柄连杆	CRANK ROD, N-BAR	
10	SA3712001	1	角滑块	SLIDE BLOCK	
11	SA2482001	1	滚针轴承	NEEDLE BEARING	
12	SA2483001	1	轴承套	CASE	
13	SA2484001	1	垫圈	WASHER, PLAIN	
14	148394000	1	针杆塞	CAP, N-BAR	
15	SA4007001	1	油毡上支架 U	FELT SUPPORT, U	
16	062500616	1	螺钉 M5X6	SCREW PAN M5X6	
17	SA3848001	1	油毡下支架 D	FELT SUPPORT, D	
18	S07465000	1	油线 L=200	WICK L=200	
19	SA3852001	1	油毡	FELT	
20	SA2485001	2	紧圈	SET SCREW COLLAR	
21	S25260001	4	固定螺钉 M6X5	SET SCREW SOCKET (FT) M6X5	
22	SA2486101	1	摆动轴轴套 R	BUSH, R	
23	062500816	1	螺钉 M5X8	SCREW PAN M5X8	
24	062061616	1	螺钉 M6X16	SCREW PAN M6X16	
25	SA2489001	1	针杆摆动连杆	NEEDLE BAR ROCKER LEVER	
26	018062032	1	螺栓 M6X20	BOLT SOCKET M6X20	
27	118735002	1	垫圈	WASHER	
28	SA2490101	1	针杆摆动杆	ROCKER LINK, N-BAR	
29	S23460001	2	螺钉 M6X5	SCREW PAN M6X5	
30	SA4117001	1	摆动杆轴 P	LINK SHAFT, N-BAR ROCKER P	
31	012060636	2	螺钉 M6X6	SET SCREW SOCKET (FT) M6X6	
32	SA4118001	1	摆动杆轴套 P	ZIGZAG LINK BUSH, P	
33	018062532	1	内六角螺栓 M6X25	BOLT SOCKET M6X25	
34	SA2493001	2	垫圈	WASHER, PLAIN	
35	SA2494001	1	针杆摆动臂	NEEDLE BAR ROCK ARM	
36	018062032	1	螺栓 M6X20	BOLT SOCKET M6X20	

D . 压脚装置 / Presser foot mechanism

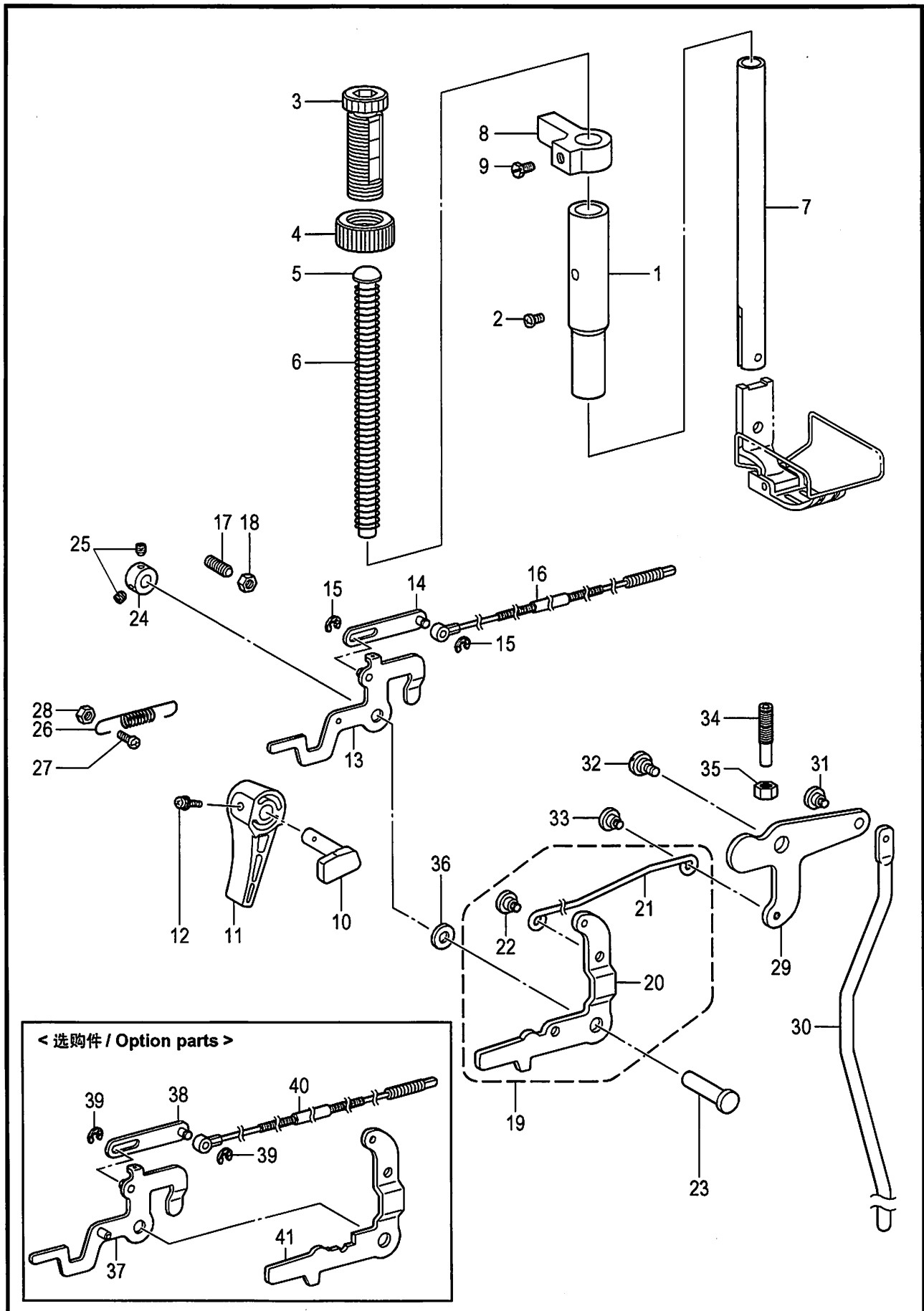

T-8722B-201

D. 压脚装置 / Presser foot mechanism

参照号	零部件序号	数量	零部件名称	NAME OF PARTS	RM
1	SA2495001	1	压杆轴套	PRESSER BAR BUSH	
2	062500816	1	螺钉 M5X8	SCREW PAN M5X8	
3	SA1174001	1	调节螺栓 M14	PRESSER ADJUSTING SCREW, M14	
4	SA1175001	1	调节螺母 M14	ADJUST SCREW NUT	
5	SA7607001	1	弹簧导杆	SPRING GUIDE	
6	S07346101	1	压紧弹簧	PRESSER BAR SPRING, -5	
7	SA2496001	1	压紧杆	PRESSER BAR	
8	SA2498001	1	压杆抱箍	GUIDE BRACKET, P-BAR	
9	S25289001	1	螺栓 M6X10	BOLT (CP) M6X10	
10	SA2499001	1	压杆提升曲柄	PRESSER BAR LIFTING CRANK	
11	S31006001	1	抬压脚扳手	LIFTING LEVER	
12	S39051001	1	螺钉(带垫圈)M3.5X12	SCREW PAN (S/P W) M3.5X12	
13	S07351001	1	松线板组件	TENSION RELEASE PLATE ASSY	
14	S07529001	1	松线连杆组件	T-RELEASE CONNECTING ROD ASSY	
15	048030342	2	挡圈 E3	RETAINING RING E3	
16	SA2677001	1	松线电线	TENSION RELEASE WIRE	
17	012061832	1	螺钉 M6X18	SET SCREW, SOCKET (FT) M6X18	
18	021060306	1	六角螺母 M6	NUT 3 M6	
19	SA2500001	1	膝控连杆组件	KNEE LIFTER C-ROD ASSY	
20	SA2501001	1	抬压脚连杆	PRESSER BAR LIFTING LEVER	
21	SA2502001	1	膝控连杆	KNEE LIFTER CONNECTING ROD	
22	SA1179001	1	段螺钉 M5	SHOULDER SCREW, M5	
23	S07349001	1	压紧杆提升杠杆销	P-BAR LIFTING LEVER SHAFT	
24	SA2504001	1	紧圈	SET SCREW COLLAR	
25	012500536	2	螺钉 M5X5	SET SCREW SOCKET (FT) M5X5	
26	S07355051	2	弹簧	SPRING, EXTENSION	
27	062501216	1	螺钉 M5X12	SCREW PAN M5X12	
28	021500106	1	六角螺母 M5	NUT 1 M5	
29	SA2506001	1	膝控提升杠杆	KNEE LIFTER LEVER	
30	SA2507001	1	膝控提升杆	KNEE LIFTER BAR	
31	SA1179001	1	段螺钉 M5	SHOULDER SCREW, M5	
32	SA2165001	1	段螺钉 M6	SHOULDER SCREW, M6	
33	SA1179001	1	段螺钉 M5	SHOULDER SCREW, M5	
34	SA4149101	1	调整螺钉 6	ADJUSTING SCREW 6	
35	021060306	1	六角螺母 M6	NUT 3 M6	
36	S07350001	1	垫圈	WASHER PLAIN	
			<选购件>	<Option parts>	
37	S10780001	1	松线板组件	TENSION RELEASE PLATE ASSY	
38	S07529001	1	松线连杆组件	T-RELEASE CONNECTING ROD ASSY	
39	048030342	2	挡圈 E3	RETAINING RING E3	
40	SA2677001	1	松线电线	TENSION RELEASE WIRE	
41	SA2578001	1	抬压脚连杆	PRESSER BAR LIFTING LEVER	

E. 送布装置 / Feed mechanism

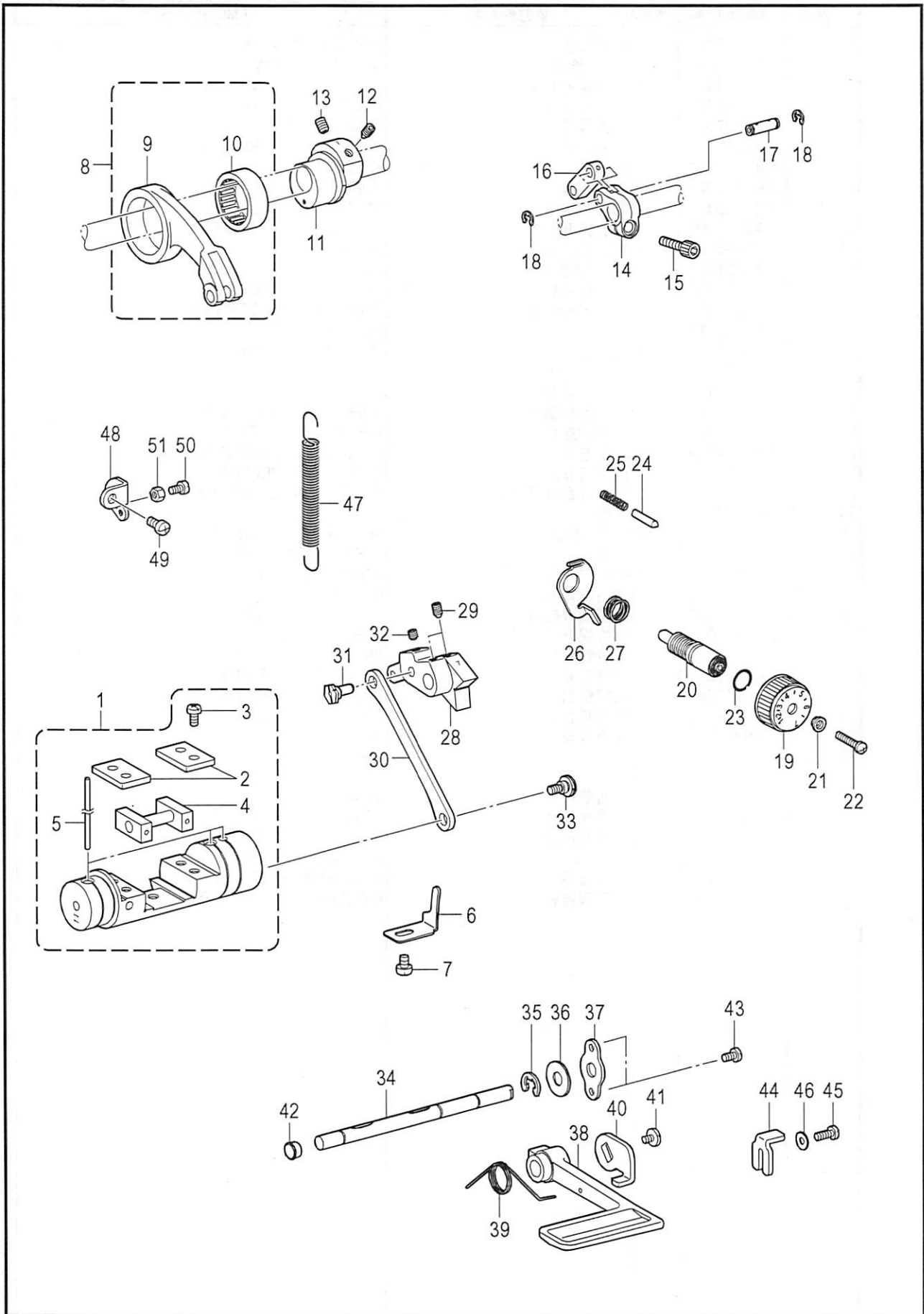

T-8722B-202

## E. 送布装置 / Feed mechanism

参照号	零部件序号	数量	零部件名称	NAME OF PARTS	RM
1	SA3062001	1	切换器11组件	FEED REGULATOR ASSY, 11	
2	SA2511001	2	滑块导向	GUIDE PLATE	
3	062501016	4	螺钉 M5X10	SCREW PAN M5X10	
4	SA2512001	1	滑块组件	SLIDE BLOCK ASSY	
5	SA2515001	3	油毡	FELT	
6	SA2516001	1	切换器定位	STOPEER	
7	062060816	1	螺钉 M6X8	SCREW PAN M6X8	
8	143611201	1	送布连杆组件	F-ROCKER CONNECTING ROD ASSY	
9	143612100	1	送布大连杆	FEED ROCKER CONNECTING ROD	
10	118954000	1	滚针轴承	NEEDLE BEARING	
11	SA2791001	1	水平偏心轮 7	LEVEL FEED ECCENTRIC WHEEL 7	
12	SA2585001	1	固定螺钉 M6X10	SET SCREW, SOCKET (FT) M6	
13	S25236001	1	螺钉 M6X10	SET SCREW SOCKET (FT) M6X10	
14	SA2793001	1	水平送料臂 7	FEED ROCKER ARM 7	
15	018062032	1	螺栓 M6X20	BOLT SOCKET M6X20	
16	143613051	1	送布小连杆	LINK	
17	143616001	1	送布曲柄轴	SHAFT	
18	048060342	2	挡圈 E6	RETAINING RING E6	
19	S38428001	1	针距标盘	STITCH LENGTH DIAL, 7	
20	SA3056001	1	调节螺栓	FEED REGULATING STUD	
21	142746122	1	针距标盘套	FEED REGULATING SUPPORTER	
22	129458202	1	螺钉 SM4.76	SCREW SM4.76	
23	108549001	1	O形圈	O RING	
24	S50098101	1	定位销	POSITIONING PIN	
25	100328001	1	止动销弹簧	NOTCH SPRING	
26	SA2523001	1	标盘锁杆	DIAL LOCK LEVER	
27	S39830101	1	弹簧	SPRING	
28	SA2796001	1	送料调节器 7	FEED REGULATOR 7	
29	016061031	2	螺钉 M6X10	SET SCREW SOCKET (CN) M6X10	
30	SA2526001	1	切换器连杆	CONNECTING ROD	
31	SA2527001	1	偏心轴	ECCENTRIC SHAFT	
32	012060636	1	螺钉 M6X6	SET SCREW SOCKET (FT) M6X6	
33	SA2528101	1	段螺钉 M6	SHOULDER SCREW M6	
34	SA2529101	1	倒缝手柄轴 TR	SHAFT, R-LEVER TR	
35	048080342	1	挡圈 E8	RETAINING RING E8	
36	025100132	1	平垫圈 S10	WASHER PLAIN S 10	
37	SA2530001	1	垫片	SPACER	
38	S07374109	1	倒缝扳手	REVERSE STITCHING LEVER	
39	SA2531001	1	弹簧	SPRING	
40	SA2541001	1	倒缝扳手板	REVERSE STITCHING LEVER PLATE	
41	SA6592001	1	螺钉 M5	SCREW M5	
42	104821001	1	橡皮塞 10.5	RUBBER CAP, 10.5	
43	062500816	2	螺钉 M5X8	SCREW PAN M5X8	
44	SA2532001	1	定位器	STOPPER	
45	062501216	1	螺钉 M5X12	SCREW PAN M5X12	
46	025050236	1	平垫圈 M5	WASHER PLAIN M 5	
47	S07376001	1	调节器弹簧	FEED REGULATOR SPRING	
48	SA2533001	1	弹簧挂钩	SPRING HOOK	
49	062060816	1	螺钉 M6X8	SCREW PAN M6X8	
50	062501216	1	螺钉 M5X12	SCREW PAN M5X12	
51	021500106	1	六角螺母 M5	NUT 1 M5	

F. 倒缝装置 / Quick reverse mechanism

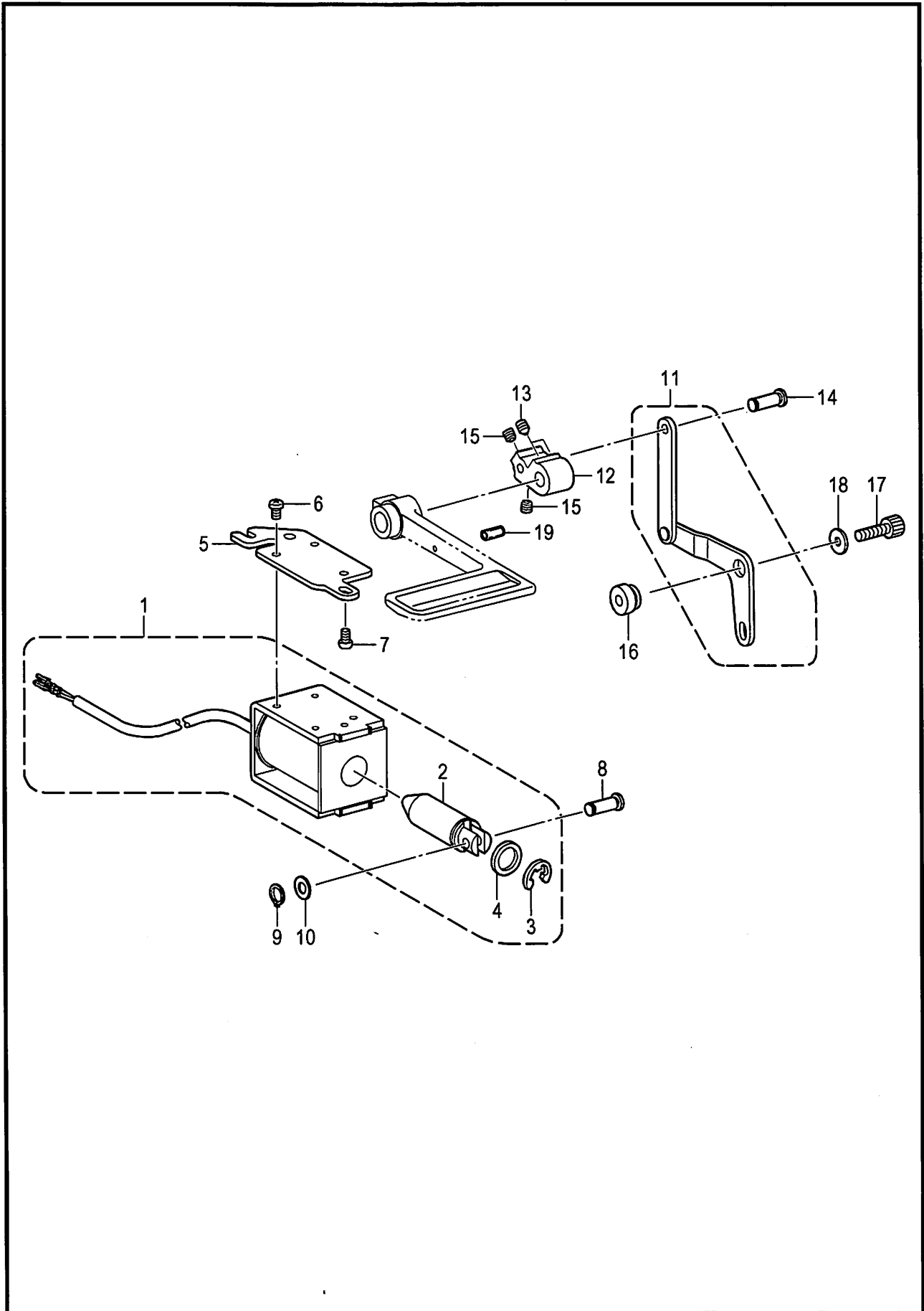

T-8722B-205



F. 倒缝装置 / Quick reverse mechanism

参照号	零部件序号	数量	零部件名称	NAME OF PARTS	RM
1	SA3072001	1	反转电磁铁组件	QUICK REVERSE SOLENOID ASSY	
2	154729001	1	柱塞	PLUNGER	
3	154730001	1	挡圈 E15	RETAINING RING E15	
4	154731000	1	橡胶垫	RUBBER STOPPER	
5	SA2535101	1	电磁铁基座	SOLENOID BRACKET	
6	062500812	3	螺钉 M5X8	SCREW PAN M5X8	
7	062061016	2	螺钉 M6X10	SCREW PAN M6X10	
8	SA2992001	1	连接销	PIN	
9	048060142	1	轴用挡圈 C6	RETAINING RING EXTERNAL C6	
10	153138001	1	垫圈 6.5	WASHER, PLAIN 6.5	
11	SA2536001	1	电磁铁曲杆组件	SOLENOID LEVER ASSY	
12	SA2540001	1	反转曲柄	QUICK REVERSE LEVER	
13	016061031	2	螺钉 M6X10	SET SCREW SOCKET (CN) M6X10	
14	SA2992001	1	连接销	PIN	
15	012060636	2	螺钉 M6X6	SET SCREW SOCKET (FT) M6X6	
16	SA2539001	1	电磁铁曲杆轴	SOLENOID LEVER SHAFT	
17	018062032	1	螺栓 M6X20	BOLT SOCKET M6X20	
18	149095001	1	垫圈 6	WASHER, PLAIN 6	
19	153132000	1	尼龙管 L=13.5	NYLON TUBE, L=13.5	

T-8722B-205

G. 送布轴装置 / Feed shaft mechanism

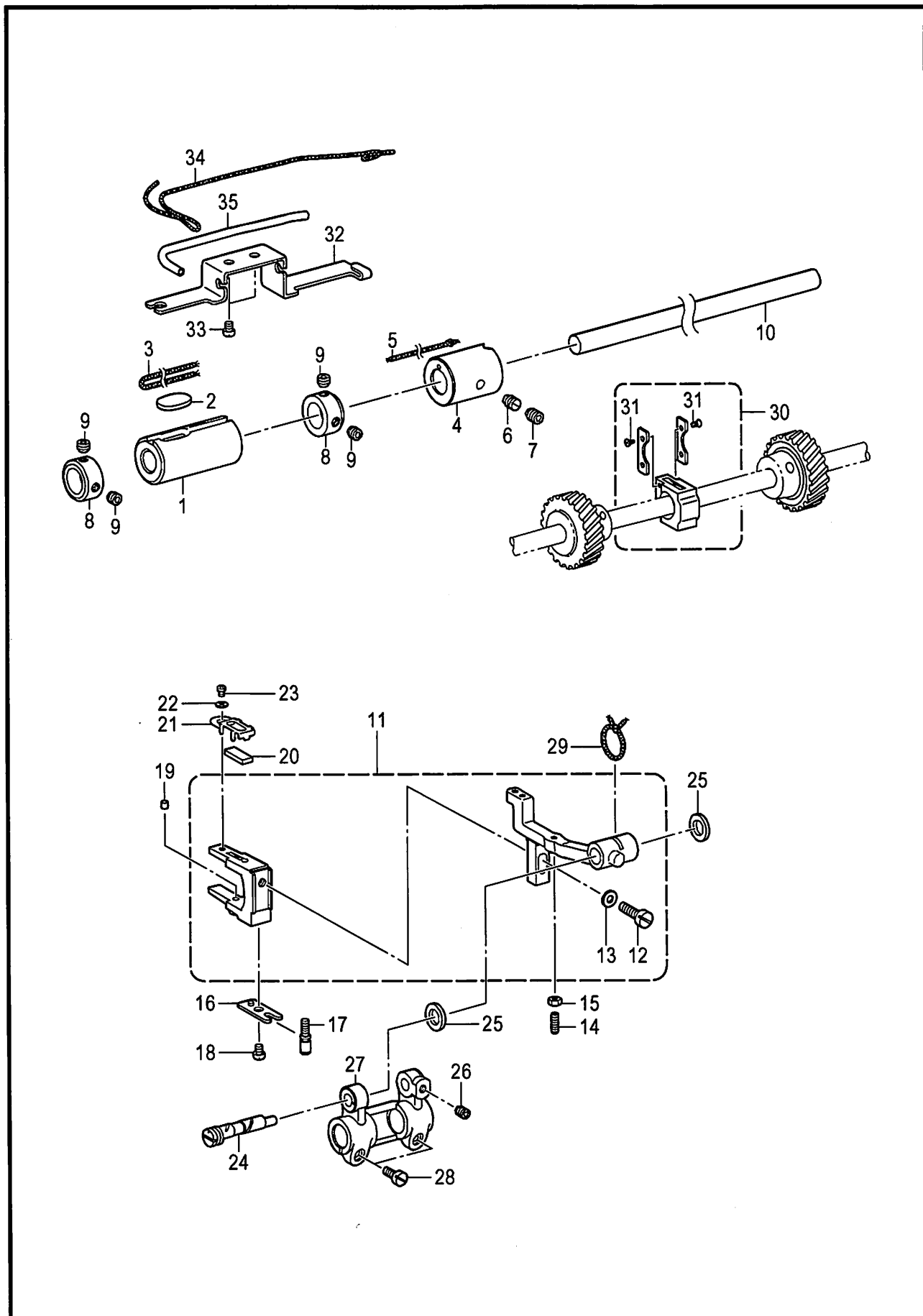

T-8722B-211

G . 送布轴装置 / Feed shaft mechanism

参照号	零部件序号	数量	零部件名称	NAME OF PARTS	RM
1	SA3855001	1	送布轴套 L	BUSH, L: F-ROCKER SHAFT	
2	SA3965001	1	油毡	FELT	
3	SA4028001	1	油线 4X4 L=220	WICK, 4X4 L=220	
4	SA2543001	1	送布轴套 R	FEED ROCKER SHAFT BUSH, R	
5	108802001	1	油线 4X4 L=250	WICK, 4X4 L=250	
6	SA2544001	1	螺钉 M6	SET SCREW M6	
7	012060636	1	螺钉 M6X6	SET SCREW SOCKET (FT) M6X6	
8	SA2546001	2	紧圈	SET SCREW COLLAR	
9	S23651001	4	固定螺钉 M6X6	SET SCREW SOCKET (FT) M6X6	
10	SA3840001	1	送布轴	FEED ROCKER SHAFT	
11	SA6150101	1	送布台叉组件 TR	FEED BAR TR FORK ASSY	
12	SA2927001	1	螺钉 M6X14	SCREW, M6X14	
13	025060132	1	平垫圈 S6	WASHER PLAIN S 6	
14	SA2566001	1	螺钉 M3.5	SET SCREW, M3.5	
15	021350106	1	螺母 M3.5	NUT 1 M3.5	
16	SA2553001	1	开叉板	FORKED PLATE	
17	SA2554001	1	调整螺栓	ADJUSTING SCREW ,HIGHT	
18	062400616	1	螺钉 M4X6	SCREW PAN M4X6	
19	SA3990001	1	油毡	FELT	
20	SA3887001	1	油毡	FELT	
21	SA3888001	1	油毡压架	FELT HOLDER	
22	025030132	1	平垫圈 S3	WASHER PLAIN S 3	
23	062300416	1	螺钉 M3X4	SCREW PAN M3X4	
24	SA2550001	1	送布台安装轴	FEED BAR SHAFT	
25	SA2551001	2	轴向垫圈	THRUST RING	
26	012060636	1	螺钉 M6X6	SET SCREW SOCKET (FT) M6X6	
27	SA2555001	1	水平送布台臂	FEED ROCKER BASE ARM	
28	SA2928001	2	螺钉 M5X12	SCREW, M5X12	
29	SA4538001	1	油线 3X3 L=200	WICK 3X3 L=200	
30	SA2806001	1	角滑块组件	FEED BAR SLIDE BLOCK ASSY	
31	SA6308001	4	螺钉 M2X4	SCREW FLAT #0 M2X4	
32	SA4009001	1	油线支架	WICK SUPPORT	
33	062400616	2	螺钉 M4X6	SCREW, PAN M4X6	
34	SA2724001	1	油线 L=400	WICK, L=400	
35	SA4011001	1	维尼龙油管 L=100	OIL TUBE, L=100	

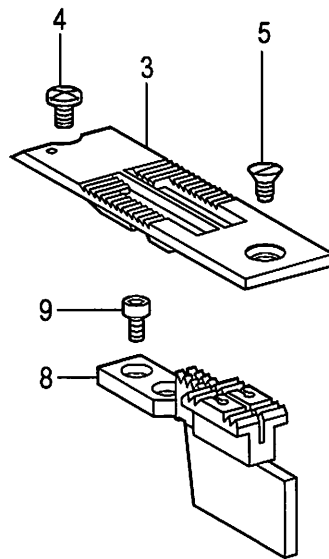
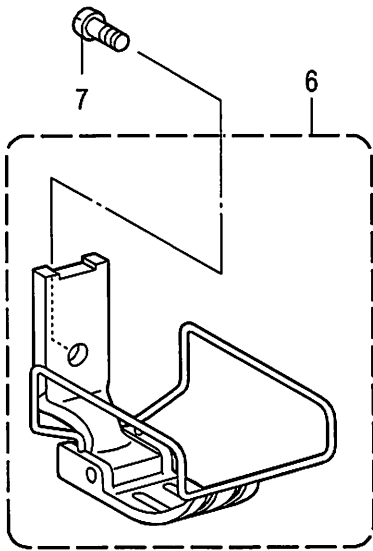
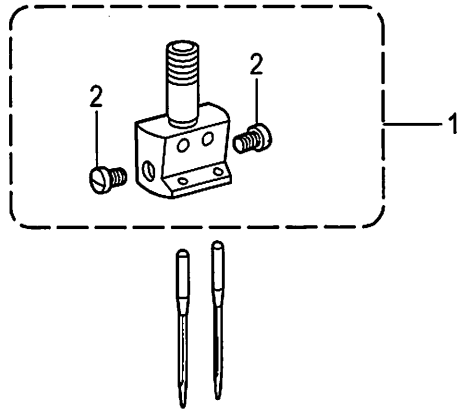

H. 定规部件 / Gauge parts

参照号	零部件序号	数量	零部件名称	NAME OF PARTS	RM
1	* P.55-56	1	针夹组件	NEEDLE CLAMP ASSY	
2	116323001	2	螺钉 SM3.57	SCREW, SM3.57	
3	* P.55-56	1	针板	NEEDLE PLATE	
4	S11244001	1	螺钉 SM4.37	SCREW, SM4.37	
5	100032004	1	平头螺钉 SM4.37-40X8	SCREW, FLAT SM4.37-40X8	
6	* P.55-56	1	压脚组件	PRESSER FOOT ASSY	
7	113050001	1	螺钉 SM3.57	SCREW, SM3.57	
8	* P.55-56	1	送布牙	FEED DOG	
9	S07494001	2	螺钉 SM3.18X7	SCREW, W/SOCKET SM3.18X7	

T-8722B-231

J1 . 旋梭装置 / Rotary hook mechanism

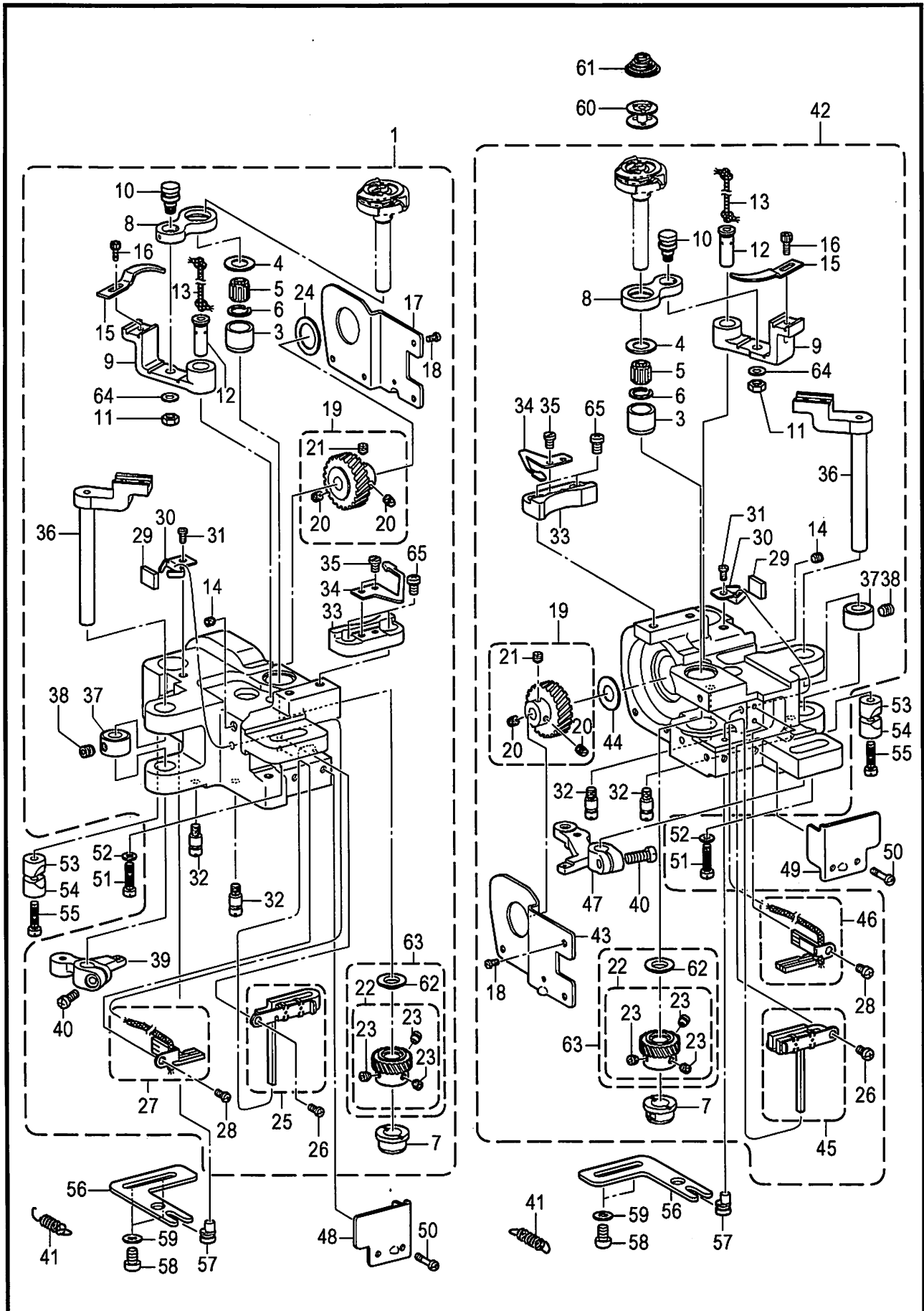

T-8722B-301

J1 . 旋梭装置 / Rotary hook mechanism

参照号	零部件序号	数量	零部件名称	NAME OF PARTS	RM
1	SA2797501	1	旋梭基座带切线组件 872TR(L)	ROTARY HOOK BASE ASSY 872TR (L)	
3	S09259001	1	旋梭轴套 U	ROTARY HOOK BUSH, U	
4	S09260001	1	轴向垫圈 A <math>t=1.2>	THRUST RING, A: 1.2MM <math>t=1.2>	
4	SA4038001	1	轴向垫圈 <math>t=1.0>	THRUST RING <math>t=1.0>	
4	S09261001	1	轴向垫圈 B <math>t=1.4>	THRUST RING, B: 1.4MM <math>t=1.4>	
4	SA4444001	1	轴向垫圈 <math>t=0.8>	THRUST RING 0.8MM <math>t=0.8>	
5	S07420000	1	滚针轴承	NEEDLE BEARING	
6	S07419001	1	止动圈	RETAINING RING	
7	SA6474001	1	旋梭轴套 D	ROTARY HOOK SHAFT BUSH	
8	SA3857001	1	分线钩连杆	OPENER LINK	
9	SA3861001	1	分线钩杆	OPENER LEVER	
10	SA2560001	1	分线钩连杆轴	SHAFT, O-LINK	
11	021500316	1	六角螺母 M5	NUT 3 M5	
12	SA3889101	1	分线钩杆短轴	O-LEVER SHAFT	
13	SA4026001	1	油线 4X4 L=100	WICK, 4X4 L=100	
14	012501031	1	螺钉 M5X10	SET SCREW SOCKET (FT) M5X10	
15	S38212001	1	分线钩	OPENER	
16	154965001	1	螺钉 SM3.57X8	BOLT, SOCKET SM3.57X8	
17	SA2562201	1	旋梭基座盖 L	ROTARY HOOK BASE COVER L	
18	062300612	4	螺钉 M3X6	SCREW PAN M3X6	
19	SA2572001	1	螺旋齿轮(带螺钉)	SPIRAL GEAR SCREW ASSY	
20	SA2574001	2	螺钉 M6	SET SCREW, (FT) M6	
21	SA2575001	1	螺钉 M6	SET SCREW, (FT) M6	
22	SA8012001	1	人字齿轮带螺钉 B	PINION GEAR SCREW ASSY B	
23	S25260001	3	固定螺钉 M6X5	SET SCREW SOCKET (FT) M6X5	
24	SA3054001	1	垫圈 L	THRUST WASHER, L	
25	SA6424101	1	油毡组件 UL	FELT UL ASSY	
26	062400616	1	螺钉 M4X6	SCREW PAN M4X6	
27	SA4044001	1	油毡组件 DL	FELT DL ASSY	
28	062400616	1	螺钉 M4X6	SCREW PAN M4X6	
29	SA4012001	1	油毡	FELT	
30	SA3894001	1	油毡架	FELT SUPPORT	
31	062400616	1	螺钉 M4X6	SCREW PAN M4X6	
32	SA2717001	2	定位螺钉	STOPPER SCREW	
33	SA2676001	1	动刀座	MOVABLE KNIFE BRACKET	
65	062400812	2	螺钉 M4X8	SCREW, PAN M4X8	
34	S07525100	1	板弹簧	SPRING PLATE	
35	141544001	2	螺钉 SM3.18-40X3	SCREW, SM3.18-40X3	
36	SA3912001	1	动刀杆	MOVABLE KNIFE LEVER	
37	SA2675001	1	紧圈	SET SCREW COLLAR	
38	S23651001	1	固定螺钉 M6X6	SET SCREW SOCKET (FT) M6X6	
39	SA2671001	1	切线杠杆 L	THREAD TRIMMER LEVER, L	
40	062501212	1	螺钉 M5X12	SCREW PAN M5X12	
62	SA6294101	1	轴向圈	THRUST RING	
63	SA7868001	1	人字齿轮复合件 B	PINION GEAR SET B	
64	025710132	1	平垫圈 S4.76	WASHER, PLAIN S 4.76	
42	SA2802501	1	旋梭基座带切线组件 872TR(R)	ROTARY HOOK BASE ASSY 872TR (R)	
3	S09259001	1	旋梭轴套 U	ROTARY HOOK BUSH, U	
4	S09260001	1	轴向垫圈 A <math>t=1.2>	THRUST RING, A: 1.2MM <math>t=1.2>	
4	SA4038001	1	轴向垫圈 <math>t=1.0>	THRUST RING <math>t=1.0>	
4	S09261001	1	轴向垫圈 B <math>t=1.4>	THRUST RING, B: 1.4MM <math>t=1.4>	
4	SA4444001	1	轴向垫圈 <math>t=0.8>	THRUST RING 0.8MM <math>t=0.8>	
5	S07420000	1	滚针轴承	NEEDLE BEARING	
6	S07419001	1	止动圈	RETAINING RING	
7	SA6474001	1	旋梭轴套 D	ROTARY HOOK SHAFT BUSH	
8	SA3857001	1	分线钩连杆	OPENER LINK	
9	SA3861001	1	分线钩杆	OPENER LEVER	
10	SA2560001	1	分线钩连杆轴	SHAFT, O-LINK	
11	021500316	1	六角螺母 M5	NUT 3 M5	
12	SA3889101	1	分线钩杆短轴	O-LEVER SHAFT	
13	SA4026001	1	油线 4X4 L=100	WICK, 4X4 L=100	
14	012501031	1	螺钉 M5X10	SET SCREW SOCKET (FT) M5X10	

T-8722B-301

J1 . 旋梭装置 / Rotary hook mechanism

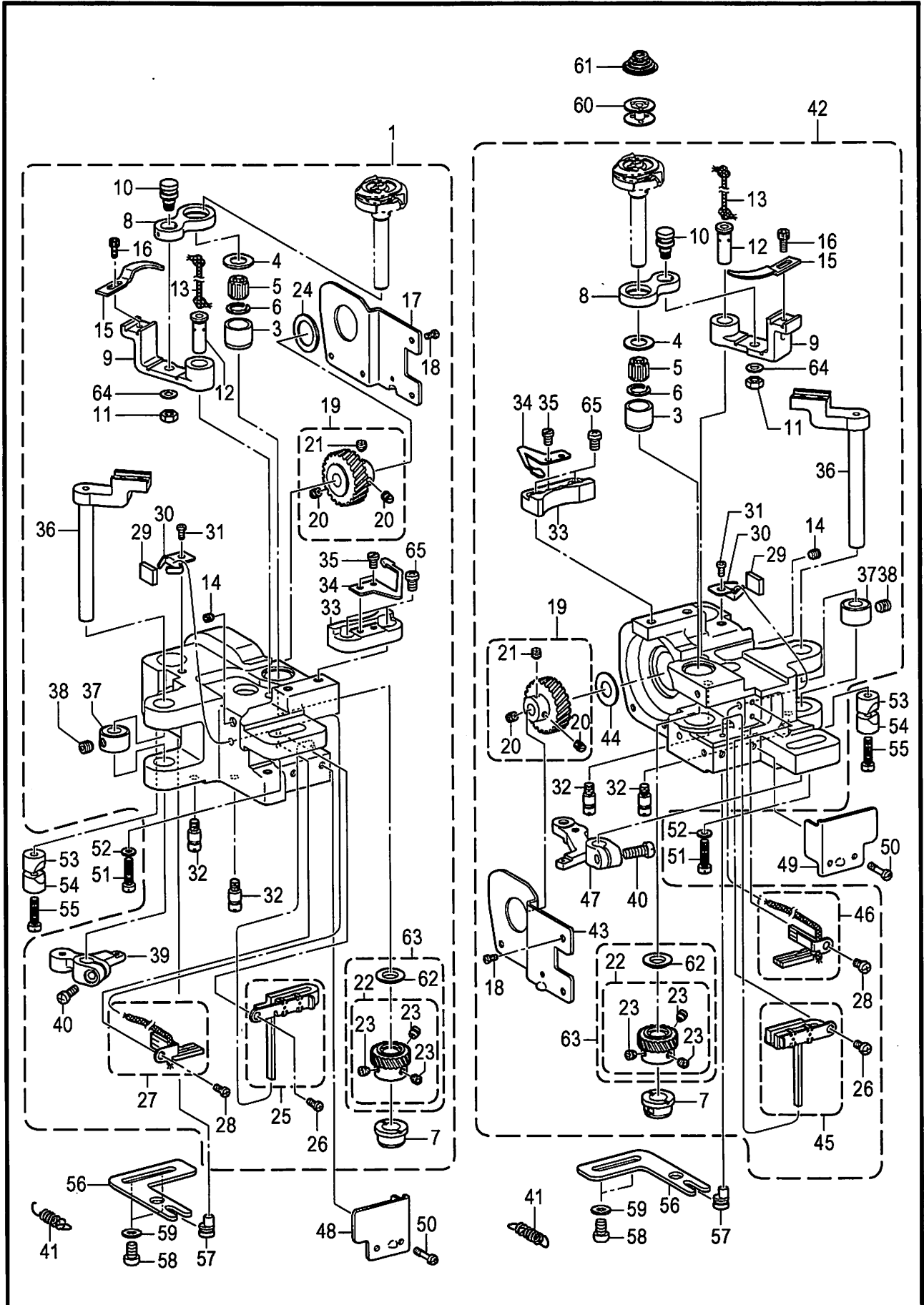

T-8722B-301



J1. 旋梭装置 / Rotary hook mechanism

参照号	零部件序号	数量	零部件名称	NAME OF PARTS	RM
15	S38212001	1	分线钩	OPENER	
16	154965001	1	螺钉 SM3.57X8	BOLT, SOCKET SM3.57X8	
43	SA2563301	1	旋梭基座盖 R	ROTARY HOOK BASE COVER R	
18	062300612	4	螺钉 M3X6	SCREW PAN M3X6	
19	SA2572001	1	螺旋齿轮(带螺钉)	SPIRAL GEAR SCREW ASSY	
20	SA2574001	2	螺钉 M6	SET SCREW, (FT) M6	
21	SA2575001	1	螺钉 M6	SET SCREW, (FT) M6	
22	SA8012001	1	人字齿轮带螺钉 B	PINION GEAR SCREW ASSY B	
23	S25260001	3	固定螺钉 M6X5	SET SCREW SOCKET (FT) M6X5	
44	SA2579001	1	垫圈	SPECER	
45	SA6425101	1	油毡组件 UR	FELT UR ASSY	
26	062400616	1	螺钉 M4X6	SCREW PAN M4X6	
46	SA4045001	1	油毡组件 DR	FELT DR ASSY	
28	062400616	1	螺钉 M4X6	SCREW PAN M4X6	
29	SA4012001	1	油毡	FELT	
30	SA3894001	1	油毡架	FELT SUPPORT	
31	062400616	1	螺钉 M4X6	SCREW PAN M4X6	
32	SA2717001	2	定位螺钉	STOPPER SCREW	
33	SA2676001	1	动刀座	MOVABLE KNIFE BRACKET	
65	062400812	2	螺钉 M4X8	SCREW, PAN M4X8	
34	S07525100	1	板弹簧	SPRING, PLATE	
35	141544001	2	螺钉 SM3.18-40X3	SCREW, SM3.18-40X3	
36	SA3912001	1	动刀杆	MOVABLE KNIFE LEVER	
37	SA2675001	1	紧圈	SET SCREW COLLAR	
38	S23651001	1	固定螺钉 M6X6	SET SCREW SOCKET (FT) M6X6	
47	SA2670101	1	切线杠杆 R	THREAD TRIMMER LEVER R	
40	062501212	1	螺钉 M5X12	SCREW PAN M5X12	
62	SA6294101	1	轴向圈	THRUST RING	
63	SA7868001	1	人字齿轮复合件 B	PINION GEAR SET B	
64	025710132	1	平垫圈 S4.76	WASHER, PLAIN S 4.76	
41	SA2826001	2	弹簧	SPRING, EXTENSION	
48	SA6462001	1	旋梭基座盖 FL	ROTARY HOOK BASE COVER FL	
49	SA6463001	1	旋梭基座盖 FR	ROTARY HOOK BASE COVER FR	
50	SA6417001	4	螺钉 M4X12	SCREW M4X12	
51	SA2556001	2	螺钉 M6X25	SCREW, M6X25	
52	115947101	2	垫圈 6.35	WASHER PLAIN 6.35	
53	SA2722001	2	套管 A	PINCH SLEEVE A	
54	SA2565001	2	套管 B	PINCH SLEEVE B	
55	SA2556001	2	螺钉 M6X25	SCREW, M6X25	
56	SA2567001	2	调节板	NEEDLE UPPER POSITIONING PLATE	
57	SA2568001	2	调节轴	NEEDLE UPPER POSITIONING SHAFT	
58	062061016	4	螺钉 M6X10	SCREW PAN M6X10	
59	025060136	4	平垫圈 S6	WASHER PLAIN S 6	
60	S09285051	2	梭芯	BOBBIN	
61	S09286000	2	防空转弹簧	ANTI-SPIN SPRING	

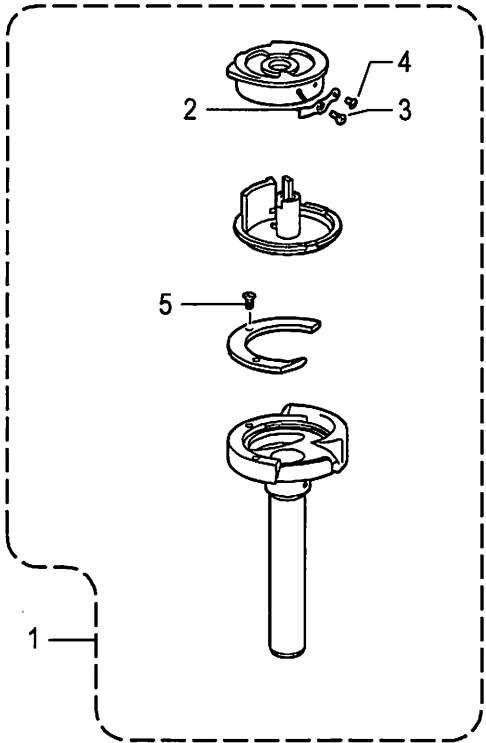

J2 . 旋梭装置 / Rotary hook mechanism

参照号	零部件序号	数量	零部件名称	NAME OF PARTS	RM
1	* P.54	1	旋梭盒组件	ROTARY HOOK ASSY	
2	155479001	1	调整簧	TENSION SPRING	
3	151029001	1	螺钉	TENSION ADJUSTING SCREW	
4	151030001	1	螺钉	SET SCREW	
5	151027001	3	螺钉	SET SCREW	

T-8722B-301

K. 下轴装置 / Lower shaft mechanism

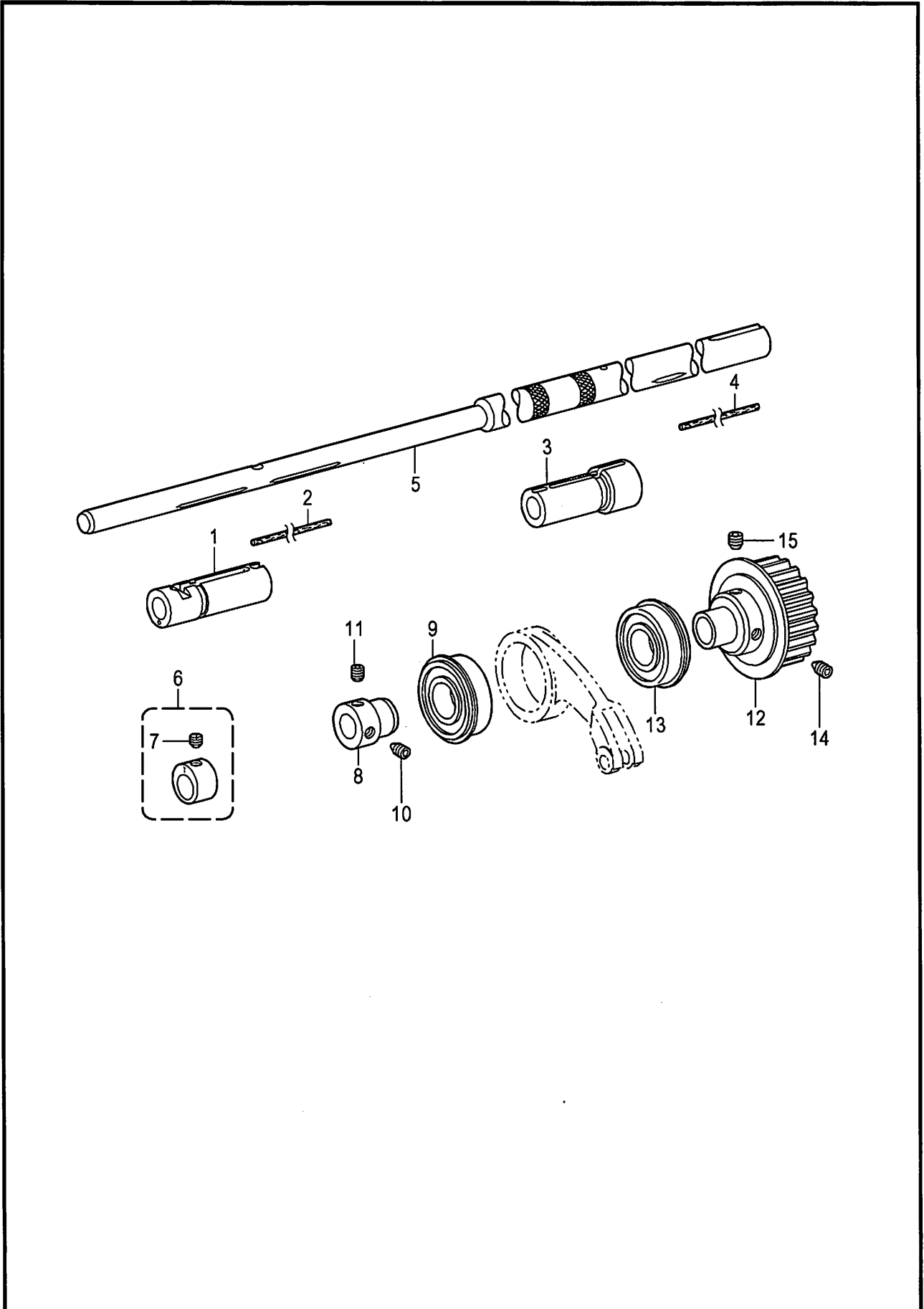

T-8722B-305

K. 下轴装置 / Lower shaft mechanism

参照号	零部件序号	数量	零部件名称	NAME OF PARTS	RM
1	SA3890001	1	旋梭基座轴套 L	ROTARY HOOK BASE BUSH, L	
2	SA4585001	1	油毡	FELT	
3	SA3891001	1	旋梭基座轴套 R	ROTARY HOOK BASE BUSH, R	
4	SA4585001	1	油毡	FELT	
5	SA2571001	1	下轴	LOWER SHAFT	
6	SA2580101	1	上下偏心轮组件	F-LIFTING ECCENTRIC WHEEL ASSY	
7	SA2575001	1	螺钉 M6	SET SCREW (FT) M6	
8	SA2584001	1	轴承套	BALL BEARING BUSH	
9	S38707001	1	球轴承 6004ZZNR	BALL BEARING, 6004ZZNR	
10	SA2585001	1	固定螺钉 M6X10	SET SCREW, SOCKET (FT) M6	
11	S23651001	1	固定螺钉 M6X6	SET SCREW SOCKET (FT) M6X6	
12	SA2587101	1	同步轮D组件	TIMING PULLEY ASSY, D	
13	158115001	1	球轴承 6204ZZNR	BALL BEARING, 6204ZZNR	
14	SA2585001	1	固定螺钉 M6X10	SET SCREW, SOCKET (FT) M6	
15	SA4213001	1	固定螺钉 M6X10	SET SCREW SOCKET (CP) M6X10	

L. 供油润滑装置 / Lubrication

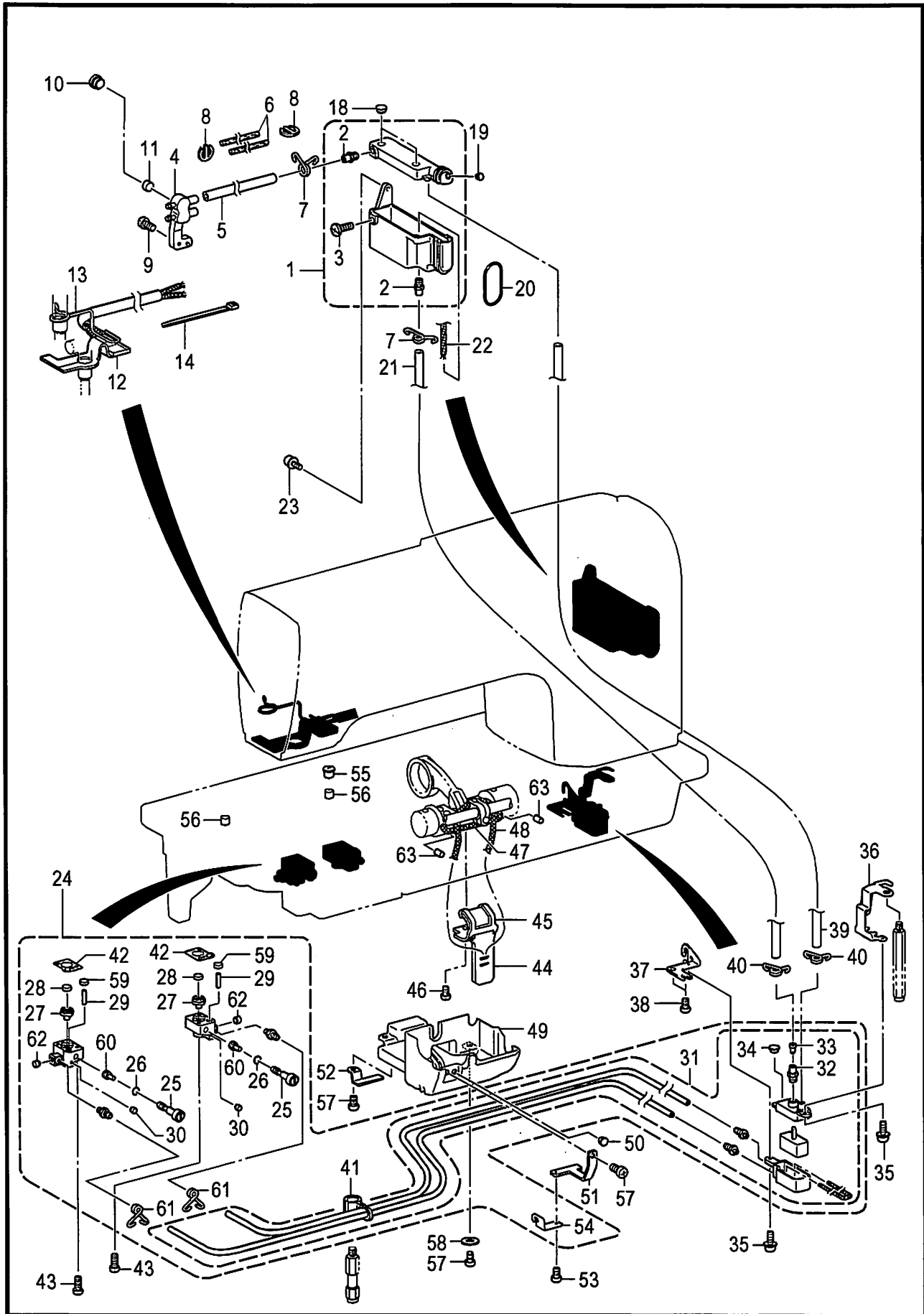

T-8722B-350

## L. 供油润滑装置 / Lubrication

参照号	零部件序号	数量	零部件名称	NAME OF PARTS	RM
1	SA4205101	1	油罐组件	OIL TANK ASSY	
2	SA3040001	2	油嘴管	OIL FEEDING PIPE	
3	SA5026101	1	螺钉 M8X7	SCREW M8X7	
4	SA3946001	1	油管接头	OIL TERMINAL	
5	SA2956001	1	维尼龙油管 L=135	OIL TUBE, L=135	
6	SA2957001	2	油毡	FELT	
7	SA3055101	2	油管夹	TUBE CLIP	
8	SA6178001	2	线夹	CLIP	
9	062500816	1	螺钉 M5X8	SCREW PAN M5X8	
10	SA2929001	2	橡皮塞 12.5	RUBBER CAP, 12.5	
11	S38266000	1	油毡	ROTARY HOOK SHAFT FELT	
12	SA4215101	1	油毡组件	FELT ASSY	
13	SA4033101	1	油毡压架	FELT SUPPORT	
14	228475000	1	电线夹 1.9X80	FASTENING BAND 1.9X80	
18	SA2929001	2	橡皮塞 12.5	RUBBER CAP, 12.5	
19	104450101	1	橡皮塞 8	RUBBER CAP, 8	
20	081038070	1	O形圈 P38	O RING P38	
21	SA2723001	1	维尼龙油管 L=210	OIL TUBE, L=210	
22	SA2724001	1	油线 L=400	WICK, L=400	
23	0A5501006	2	螺栓(带垫圈) M5X10DB	SCREW PAN (S/P WASHER) M5X10	
24	SA7540001	1	供油部分复合件	OIL BLOCK SET	
25	SA6475001	2	供油调节螺钉	OIL ADJUSTING SCREW	
26	081004070	2	O形圈 P4	O RING P4	
27	SA6468001	2	橡皮垫圈	RUBBER PACKING	
28	SA6423001	2	旋梭轴油毡	ROTARY HOOK SHAFT FELT	
29	SA6415001	2	油线 L=80	WICK L=80	
30	142274101	2	橡皮塞 4.2	RUBBER CAP, 4.2	
31	SA7548001	1	副油罐复合件	SUB-TANK SET	
32	SA3040001	1	油嘴管	OIL FEEDING PIPE	
33	SA3060001	1	油门垫片	VALVE PACKING	
34	104450101	1	橡皮塞 8	RUBBER CAP, 8	
35	0A4400806	2	螺栓(带垫圈) M4X8DA	SCREW PAN (S/P WASHER) M4X8	
36	SA3045201	1	副油罐安装架 A	SUB-TANK SETTING PLATE A	
37	SA3046001	1	副油罐安装架 B	SUB-TANK SETTING PLATE, B	
38	062060816	2	螺钉 M6X8	SCREW PAN M6X8	
39	SA3044001	1	维尼龙油管 L=242	OIL TUBE, L=242	
40	SA3055101	2	油管夹	TUBE CLIP	
41	SA6472001	1	油管支架	TUBE SUPPORT	
42	SA3923101	2	旋梭基座D垫片	ROTARY HOOK BASE D PACKING	
43	062401616	4	螺钉 M4X16	SCREW PAN M4X16	
44	SA2604001	1	油毡	FEED REGULATOR FELT	
45	SA2605001	1	油毡压架	FELT SUPPORT	
46	062500616	1	螺钉 M5X6	SCREW PAN M5X6	
47	109405001	1	油线 4X4 L=100	WICK 4X4 (L=100)	
48	108801001	1	油线 4X4 L=350	WICK, 4X4 L=350	
49	SA2606101	1	油盖	OIL COVER	
50	104450101	1	橡皮塞 8	RUBBER CAP, 8	
51	SA3048101	1	油管压架 A	TUBE SUPPORT, A	
52	SA3049001	1	油管压架 B	TUBE SUPPORT, B	
53	062400616	1	螺钉 M4X6	SCREW PAN M4X6	
54	SA6473001	1	油管导向	TUBE GUIDE	
55	140890009	1	油盖	OIL CAP	
56	112753001	2	油毡	FELT	

L. 供油润滑装置 / Lubrication

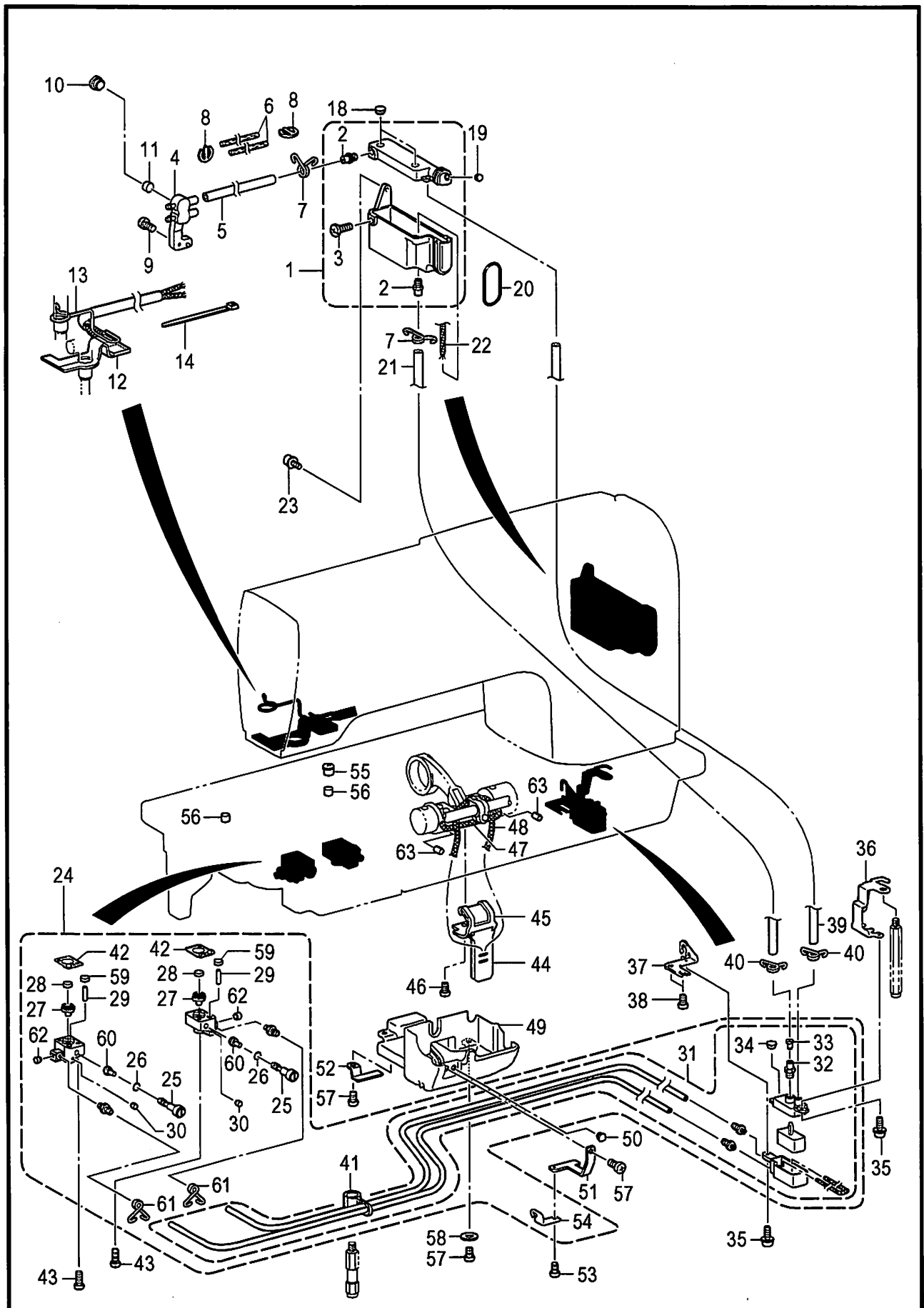

T-8722B-350



L. 供油润滑装置 / Lubrication

参照号	零部件序号	数量	零部件名称	NAME OF PARTS	RM
57	062061016	3	螺钉 M6X10	SCREW PAN M6X10	
58	025060236	1	平垫圈 M6	WASHER PLAIN M 6	
59	SA6423001	2	旋梭轴油毡	ROTARY HOOK SHAFT FELT	
60	SA6416001	2	柱塞	RUBBER PRESSER	
61	SA6414001	2	油管夹	TUBE CLIP	
62	140327001	2	橡皮塞 6.3	RUBBER CAP, 6.3	
63	148743001	2	油毡	FELT	

T-8722B-350

M . 穿线装置 / Threading mechanism

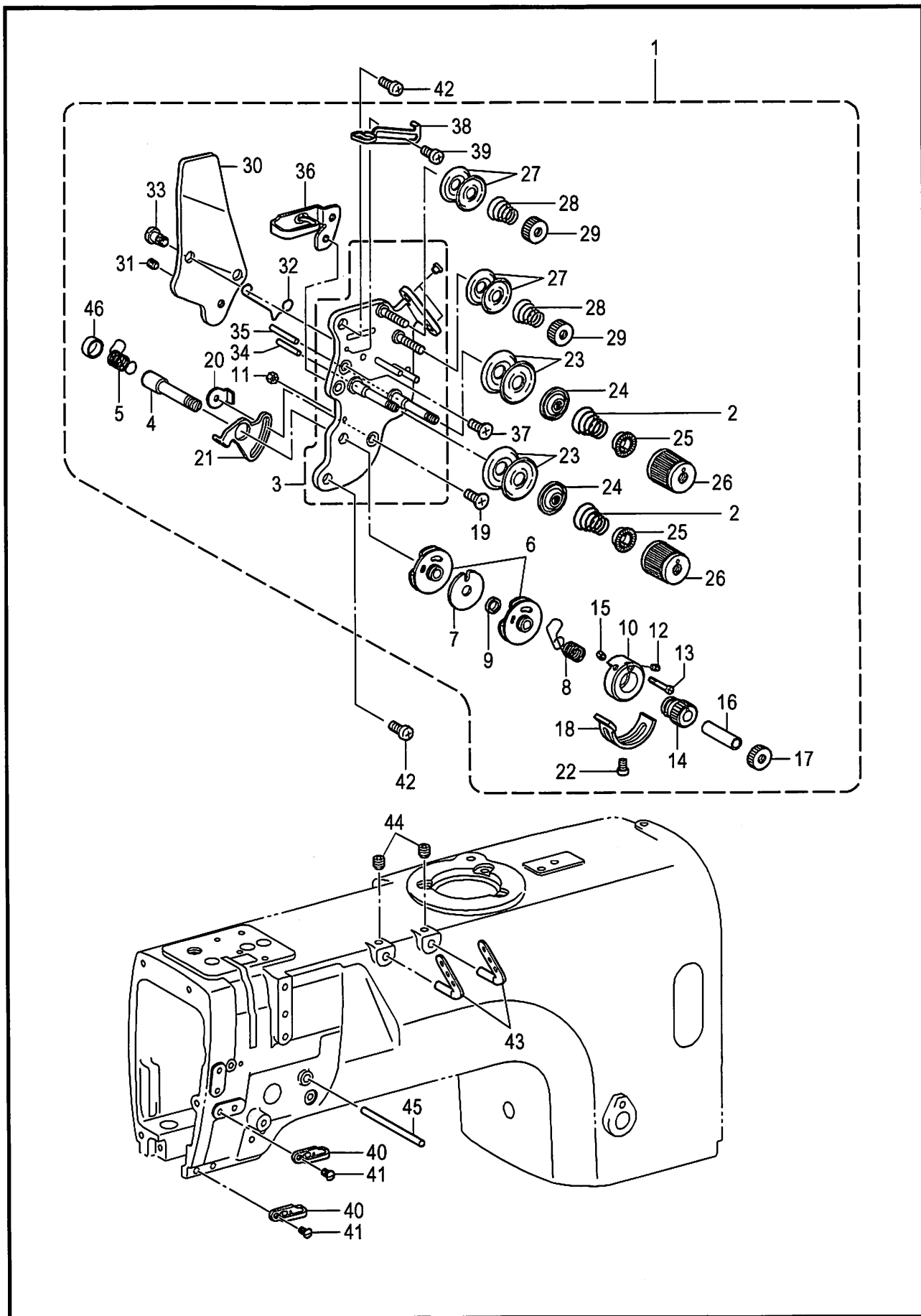

T-8722B-401

M . 穿线装置 / Threading mechanism

参照号	零部件序号	数量	零部件名称	NAME OF PARTS	RM
			<用于-403>	<For -403>	
1	SA3417301	1	面线调节组件 -3	UPPER THREAD TENSION ASSY -3	
2	SA3415001	2	弹簧 L	TENSION SPRING, L	
			<用于-405>	<For -405>	
1	SA2607301	1	面线调节组件 -5	UPPER THREAD TENSION ASSY -5	
2	SA3416101	2	弹簧 LL	TENSION SPRING LL	
3	SA4212001	1	调整台组件	TENSION PLATE ASSY	
4	SA2613001	1	调整短轴	TENSION STUD	
5	SA2614201	1	弹簧 L	THREAD TAKE-UP SPRING L	
6	SA2615001	2	导向组件	GUIDE ASSY, T/TAKE-UP SPRING	
7	SA2619001	1	垫片	SPACER	
8	SA2623201	1	弹簧 R	THREAD TAKE-UP SPRING R	
9	SA2620001	1	轴套	COLLAR	
10	SA2621001	1	定位圈	STOPPER SUPPORT	
11	021300106	1	螺母 M3	NUT 1 M3	
12	SA2626001	1	螺钉 M3.5	SET SCREW, (CP) M3.5	
13	SA2624001	1	固定螺栓	SPRING GUIDE SET SCREW	
14	SA2625001	1	调节旋钮	ADJUSTING THUMB	
15	SA2626001	1	螺钉 M3.5	SET SCREW, (CP) M3.5	
16	SA2627001	1	轴套	COLLAR	
17	SA2628001	1	调线螺母	TENSION NUT	
18	SA2629001	1	弹簧限位板	STOPPER	
19	061350616	1	螺钉 M3.5X6	SCREW FLAT M3.5X6	
20	SA2824001	1	定位螺母 M3.5	NUT, WHIRL-STOP M3.5	
21	SA2630001	1	限位板	STOPPER	
22	062350512	1	螺钉 M3.5X5	SCREW PAN M3.5X5	
23	145446001	4	夹线盘	DISC, TENSION	
24	159805001	2	夹线压盘	TENSION DISC PRESSER	
25	S20681000	2	调节弹簧垫圈	WASHER	
26	S20682105	2	调节螺母	TENSION NUT	
27	144504001	4	导向盘	THREAD GUIDE DISC	
28	154560101	2	小夹线弹簧 A	PRE-TENSION SPRING A	
29	155510001	2	夹线螺母	TENSION NUT	
30	SA2632001	1	松线板	TENSION RELEASE PLATE	
31	012500536	1	螺钉 M5X5	SET SCREW SOCKET (FT) M5X5	
32	S38274001	1	松线弹簧	T-RELEASE SPRING	
33	SA2633001	2	段螺钉 M3.5	SHOULDER SCREW, M3.5	
34	SA4506001	1	松线销 L	TENSION RELEASE PIN, L	
35	SA4507001	1	松线销 R	TENSION RELEASE PIN, R	
36	SA2634001	1	线导向 U	THREAD GUIDE, U :ARM	
37	061350616	2	螺钉 M3.5X6	SCREW FLAT M3.5X6	
38	SA2635001	1	线调整	THREAD QUANTITY ADJUST	
39	062300616	1	螺钉 M3X6	SCREW PAN M3X6	
46	SA6378001	1	盖	CAP	
40	SA2638001	2	线导向 M	THREAD GUIDE, M :ARM	
41	SA2640001	2	螺钉 M5X8	SCREW FLAT M5X8	
42	062500816	2	螺钉 M5X8	SCREW PAN M5X8	
43	SA2636001	2	三眼线勾	THREAD RETAINER	
44	012060636	2	螺钉 M6X6	SET SCREW SOCKET (FT) M6X6	
45	SA2637001	1	松线轴	BAR, TENSION RELEASE	

T-8722B-401

N. 卷线装置 / Bobbin winder mechanism

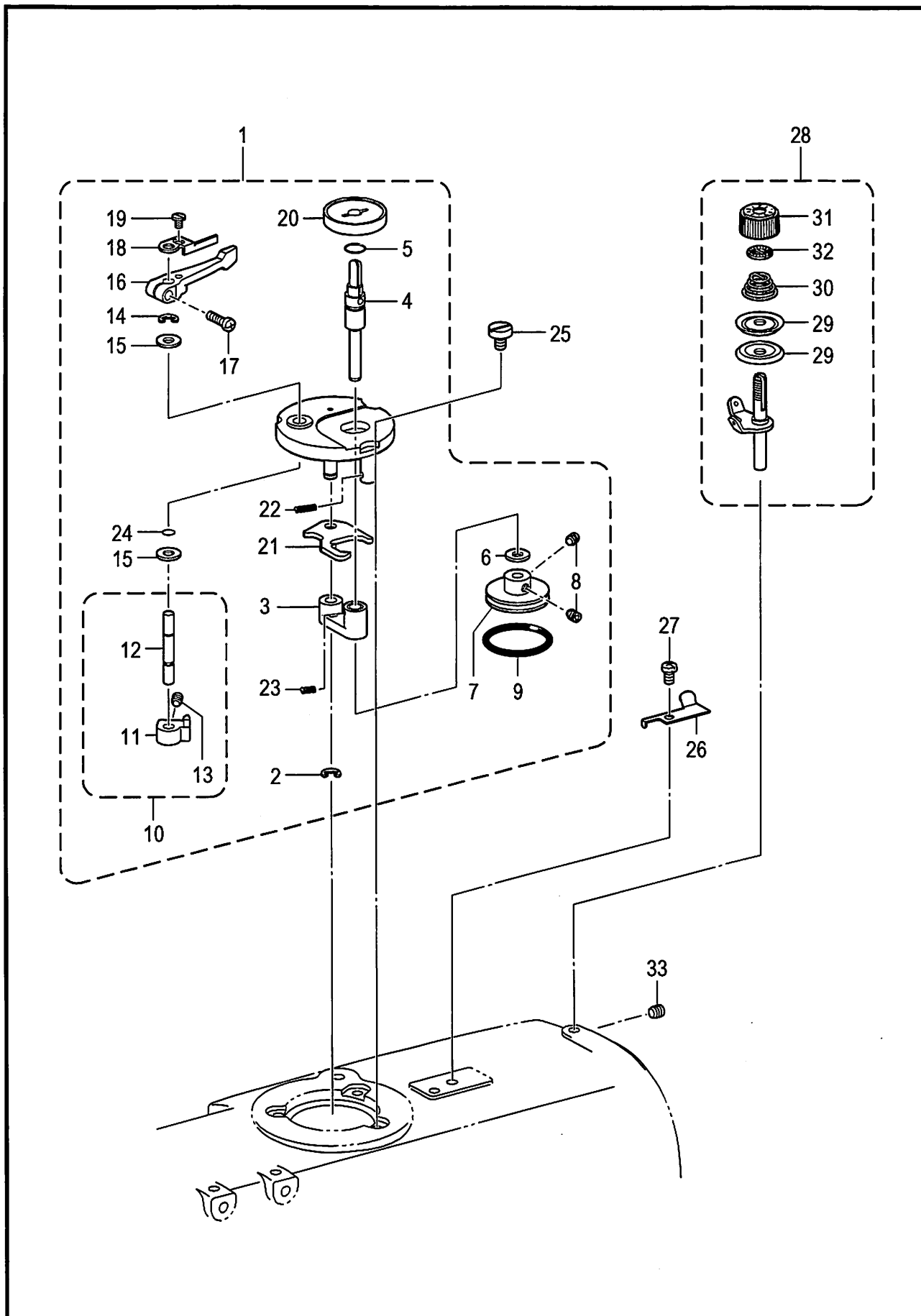

T-8722B-402

N . 卷线装置 / Bobbin winder mechanism

参照号	零部件序号	数量	零部件名称	NAME OF PARTS	RM
1	SA1971101	1	卷线器组合件	BOBBIN WINDER UNIT	
2	048040342	1	挡圈 E4	RETAINING RING E4	
3	SA1975001	1	卷线轴基座组件	B-WINDER SHAFT SUPPORT ASSY	
4	SA1978001	1	卷线轴	BOBBIN WINDER SHAFT	
5	081009070	1	O形圈 P9	O RING P9	
6	025060136	1	平垫圈 S6	WASHER PLAIN S 6	
7	SA1980001	1	卷线轮	BOBBIN WINDER WHEEL	
8	012500536	2	螺钉 M5X5	SET SCREW SOCKET (FT) M5X5	
9	S25789000	1	橡皮垫圈 29	RUBBER RING, 29	
10	SA1981101	1	梭芯夹凸轮组件	BOBBIN PRESSER CAM ASSY	
11	SA1982101	1	梭芯夹凸轮	BOBBIN PRESSER CAM	
12	SA1983001	1	梭芯夹轴	BOBBIN WINDER ARM SHAFT	
13	012500536	1	螺钉 M5X5	SET SCREW SOCKET (FT) M5X5	
14	048040342	1	挡圈 E4	RETAINING RING E4	
15	025060136	2	平垫圈 S6	WASHER PLAIN S 6	
16	SA1984001	1	梭芯压臂柄	BOBBIN PRESSER ARM	
17	062401216	1	螺钉 M4X12	SCREW PAN M4X12	
18	SA1985001	1	梭芯夹	BOBBIN PRESSER	
19	S23418002	1	螺钉 M4X5	SCREW, M4X5	
20	SA1988001	1	梭芯座	BOBBIN SUPPORT	
21	SA1989001	1	卷线杠杆	BOBBIN WINDER LEVER	
22	SA1990101	1	弹簧	SPRING	
23	SA1991001	1	弹簧	BOBBIN WINDER BASE SPRING	
24	SA2190001	1	O形密封圈 SS5	O RING, SS5	
25	SA1992101	3	固定螺钉	BOBBIN WINDER FIXED SCREW	
26	SA1360101	1	切刀	KNIFE	
27	062500616	1	螺钉 M5X6	SCREW PAN M5X6	
28	SA1994101	1	卷线器夹线组件	BOBBIN WINDER TENSION ASSY	
29	145446002	2	夹线盘	DISC, TENSION	
30	100401022	1	夹线弹簧	TENSION SPRING	
31	S31032001	1	压线螺母	TENSION NUT	
32	S12441001	1	止动垫圈	WASHER	
33	012500536	1	螺钉 M5X5	SET SCREW SOCKET (FT) M5X5	

P. 切线装置 / Thread trimmer mechanism

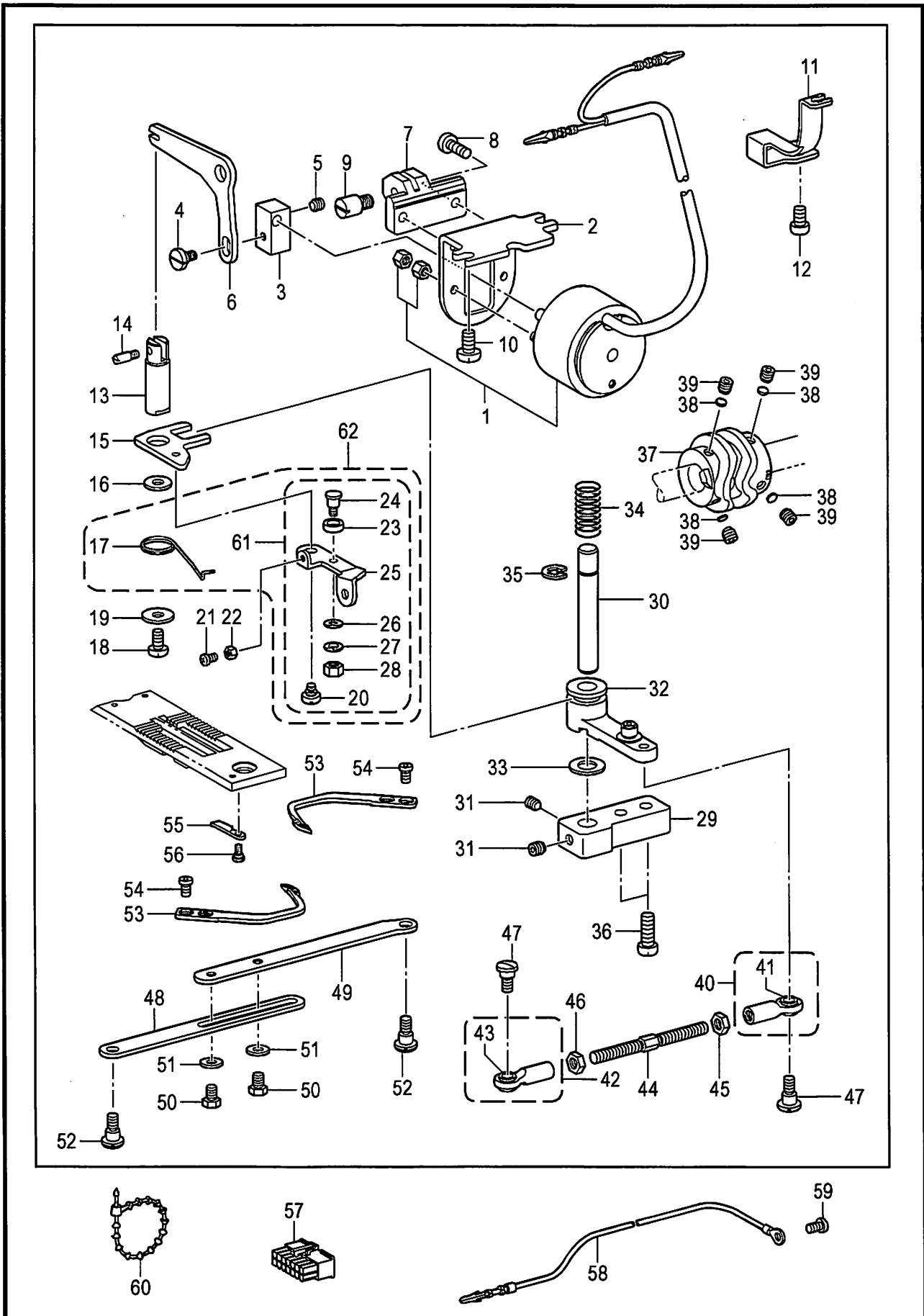

T-8722B-403

P. 切线装置 / Thread trimmer mechanism

参照号	零部件序号	数量	零部件名称	NAME OF PARTS	RM
1	SA2642001	1	切线电磁铁	THREAD TRIMMER SOLENOID	
2	SA2643001	1	电磁铁架	SOLENOID BRACKET	
3	SA2644001	1	电磁铁接头	SOLENOID JOINT	
4	SA2645001	1	段螺钉 M5	SHOULDER SCREW, M5	
5	012500536	1	螺钉 M5X5	SET SCREW SOCKET (FT) M5X5	
6	SA2646001	1	电磁铁杆	SOLENOID LEVER	
7	SA2728001	1	电磁铁杆支承架	SOLENOID LEVERB RACKET	
8	062501016	2	螺钉 M5X10	SCREW PAN M5X10	
9	SA2647001	1	电磁铁杆短轴	SOLENOID LEVER SHAFT	
10	062061012	2	螺钉 M6X10	SCREW PAN M6X10	
11	SA2648001	1	线夹	CORD HOLDER	
12	062060816	1	螺钉 M6X8	SCREW PAN M6X8	
13	SA2651001	1	切线轴	DRIVING ROD	
14	148546001	1	销	PLUNGER PIN	
15	SA2652101	1	切线轴板	DRIVING ROD PLATE, TR	
16	SA2860001	1	垫圈	WASHER	
17	SA6395001	1	弹簧	SPRING	
18	062501016	1	螺钉 M5X10	SCREW PAN M5X10	
19	116662003	1	垫圈	WASHER	
20	SA2655001	1	段螺钉 M4	SHOULDER SCREW, M4	
21	062351216	1	螺钉 M3.5X12	SCREW PAN M3.5X12	
22	021350106	1	螺母 M3.5	NUT 1 M3.5	
23	SA6392001	1	松线滚轮	ROLLER	
24	SA6393001	1	滚轮轴	ROLLER SHAFT	
25	SA6394001	1	松线杆	TENSION RELEASE LEVER	
26	113431002	1	垫圈	WASHER, PLAIN	
27	028050246	1	弹簧垫圈 2-5	WASHER SPRING 2-5	
28	021500106	1	六角螺母 M5	NUT 1 M5	
29	SA2657001	1	主杆轴架	MAIN LEVER SUPPORT SHAFT	
30	SA2658001	1	主杆轴	MAIN LEVER SHAFT	
31	012060636	2	螺钉 M6X6	SET SCREW SOCKET (FT) M6X6	
32	SA2659001	1	主杆组件	MAIN LEVER ASSY	
33	148559100	1	橡胶	RUBBER	
34	S07509001	1	弹簧	MAIN LEVER SPRING	
35	048070342	1	挡圈 E7	RETAINING RING E7	
36	062061616	2	螺钉 M6X16	SCREW PAN M6X16	
37	SA2661001	1	切线凸轮	THREAD TRIMMER CAM	
38	SA2378001	4	垫片 4.8	SPACER, 4.8	
39	S25236001	4	螺钉 M6X10	SET SCREW SOCKET (FT) M6X10	
40	SA2663001	1	接头组件 R	ROUND JOINT ASSY R	
41	141331002	1	管套	BUSH	
42	SA2665001	1	接头组件 L	ROUND JOINT ASSY L	
43	141331002	1	管套	BUSH	
44	SA2667001	1	长度调节连杆	L-ADJUSTING CONNECTING ROD	
45	021060306	1	六角螺母 M6	NUT 3 M6	
46	SA2668001	1	螺母 M6(L)	NUT M6 LEFT	
47	SA2669001	2	段螺钉 SM5.95-28	SHOULDER SCREW, SM5.95-28	
48	SA2672001	1	切线连杆 R	T-TRIMMER CONNECTING ROD, R	
49	SA2673001	1	切线连杆 L	T-TRIMMER CONNECTING ROD, L	
50	017500812	2	六角螺栓 M5X8	BOLT M5X8	
51	025050236	2	平垫圈 M5	WASHER PLAIN M 5	
52	SA2645001	2	段螺钉 M5	SHOULDER SCREW, M5	
53	S07526301	2	动刀	MOVABLE KNIFE	
54	148536001	4	螺钉 SM4.37-40X4.2	SCREW, W/SOCKET SM4.37-40X4.2	
55	S07527001	2	定刀	FIXED KNIFE	
56	148539101	2	段螺钉 SM2.38	SHOULDER SCREW, SM2.38	
61	SA8364001	1	松线杆组件	TENSION RELEASE LEVER ASSY	
62	SA8365001	1	松线杆复合件	TENSION RELEASE LEVER SET	
57	S38687000	1	插头 5557-14R	CONNECTOR, 5557-14R	
58	SA1998001	1	接地线组件	GROUND WIRE ASSY	
59	062500816	1	螺钉 M5X8	SCREW PAN M5X8	
60	340400001	2	线夹	BEAD BAND	

T-8722B-403

Q . 松线装置 / Tension release mechanism

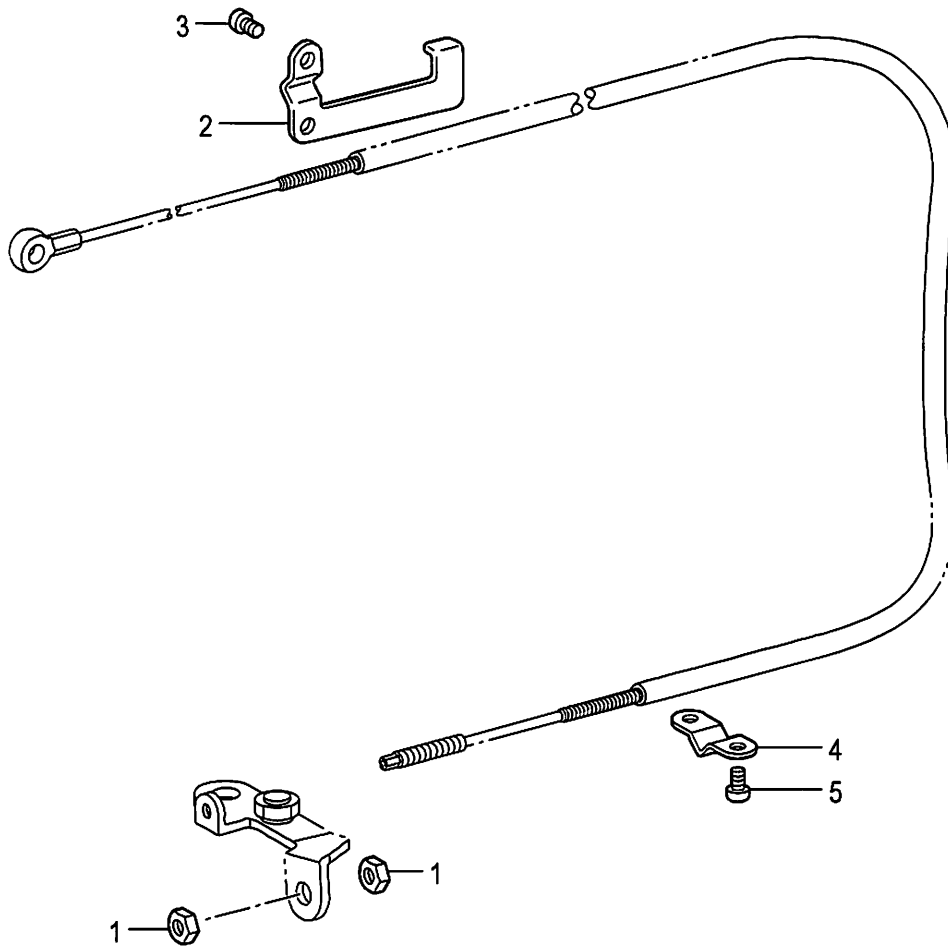

T-8722B-404



Q . 松线装置 / Tension release mechanism

参照号	零部件序号	数量	零部件名称	NAME OF PARTS	RM
1	110161004	2	螺母 SM4.76	NUT, SM4.76	
2	SA2678001	1	松线电线夹	TENSION RELEASE WIRE HOLDER	
3	062500816	2	螺钉 M5X8	SCREW PAN M5X8	
4	SA2679001	1	松线电线夹	TENSION RELEASE WIRE HOLDER	
5	062060816	2	螺钉 M6X8	SCREW PAN M6X8	

T-8722B-404

R. 扫线装置 / Thread wiper mechanism

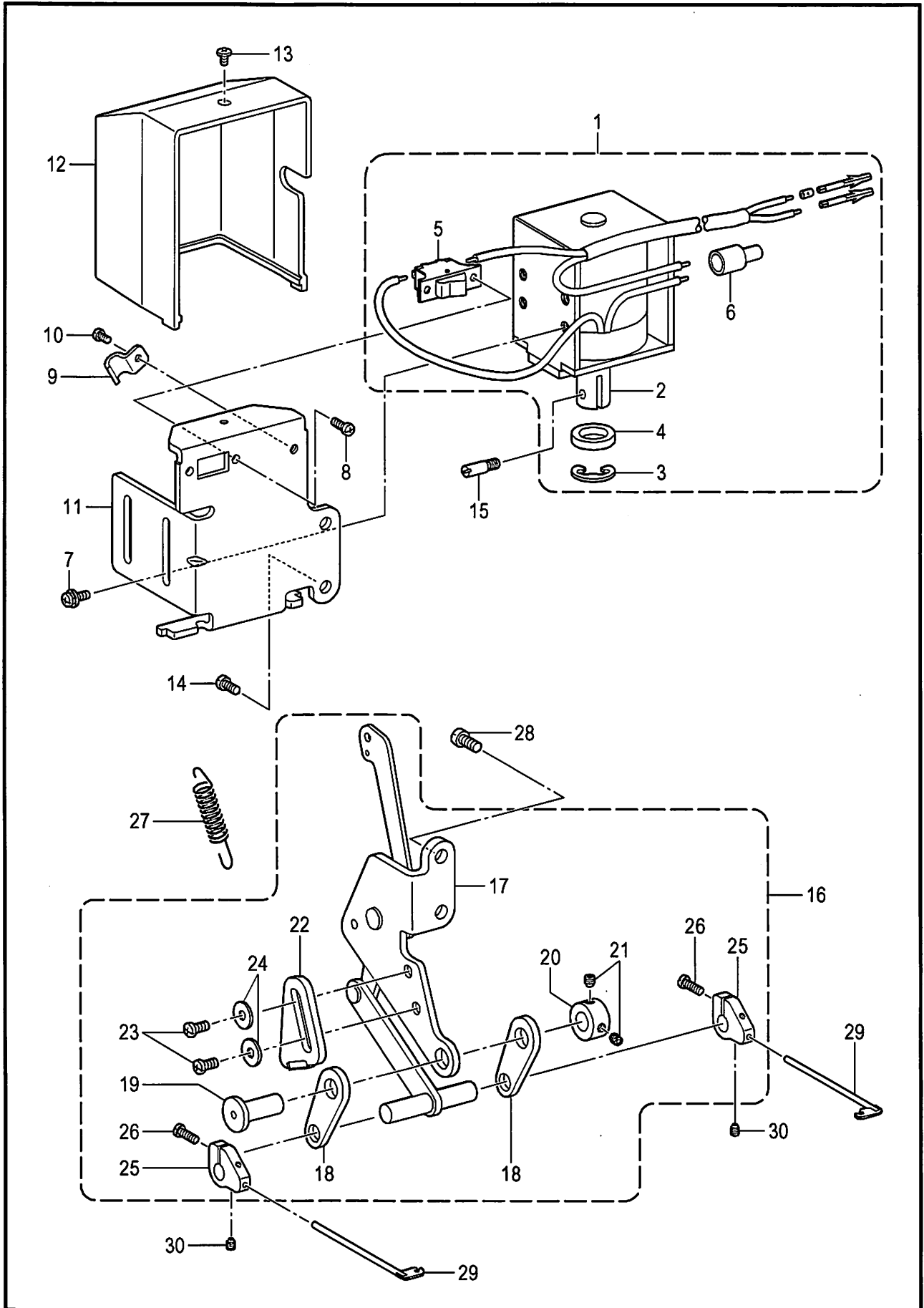

T-8722B-405

## R. 扫线装置 / Thread wiper mechanism

参照号	零部件序号	数量	零部件名称	NAME OF PARTS	RM
1	SA2680001	1	扫线电磁铁组件	THREAD WIPER SOLENOID ASSY	
2	148511001	1	插棒式铁芯	PLUNGER	
3	048090342	1	挡圈 E9	RETAINING RING E9	
4	S38426000	1	橡皮垫	PLUNGER RUBBER	
5	S02664001	1	挡线开关	THREAD WIPER SWITCH	
6	S02665000	1	电线接头	TERMINAL CONNECTOR	
7	S39048001	4	螺钉(带垫片) M4X10	SCREW, PAN (S/P W) M4X10	
8	062300616	2	螺钉 M3X6	SCREW PAN M3X6	
9	140647101	1	电线固定夹	CORD HOLDER	
10	062400616	1	螺钉 M4X6	SCREW PAN M4X6	
11	SA2732001	1	电磁铁安装板	SOLENOID HOLDING PLATE	
12	SA2696001	1	电磁铁盖	SOLENOID COVER	
13	060400516	1	螺钉 M4X5	SCREW BIND M4X5	
14	062501016	2	螺钉 M5X10	SCREW PAN M5X10	
15	148546001	1	销	PLUNGER PIN	
16	SA2682001	1	电磁铁连杆组件	THREAD WIPER LINK ASSY	
17	SA2683001	1	电磁铁连杆	SOLENOID LINK	
18	S07549101	2	连接板 C	THREAD WIPER LINK, C	
19	S07550001	1	连接板轴	LINK STUD	
20	SA2504001	1	紧圈	SET SCREW COLLAR	
21	012500536	2	螺钉 M5X5	SET SCREW SOCKET (FT) M5X5	
22	SA8745001	1	定位板	STOPPER	
23	062500816	2	螺钉 M5X8	SCREW PAN M5X8	
24	025050236	2	平垫圈 M5	WASHER PLAIN M 5	
25	S07552101	2	扫线器架	THREAD WIPER SUPPORT	
26	062661212	2	螺钉 SM3.18-40X12	SCREW PAN SM3.18-40X12	
27	SA2684001	1	弹簧	THREAD WIPER SPRING	
28	062501016	2	螺钉 M5X10	SCREW PAN M5X10	
29	S07553001	2	扫线器	THREAD WIPER	
30	S07424001	2	螺钉 SM3.18X4	SET SCREW, W/SOCKET SM3.18X4	

S1 . 控制箱和马达装置 / Control box and motor mechanism

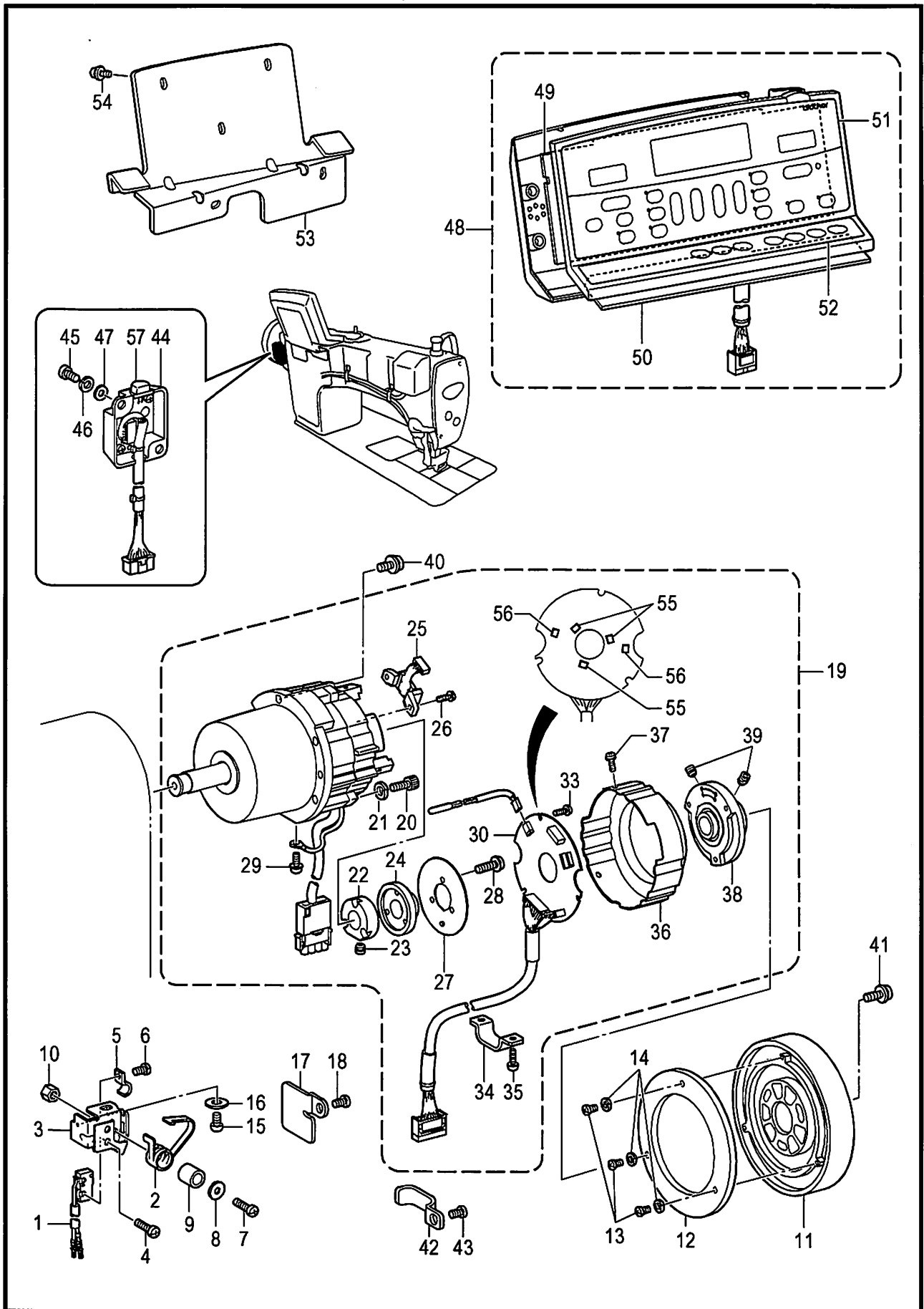

T-8722B-502

S1. 控制箱和马达装置 / Control box and motor mechanism

参照号	零部件序号	数量	零部件名称	NAME OF PARTS	RM
1	SA1385001	1	微处理开关组件	MICRO SWITCH ASSY	
2	S38744101	1	板弹簧	SWITCH PLATE SPRING	
3	SA2686001	1	开关基座	SWITCH BASE	
4	062020806	2	螺钉 M2X8	SCREW PAN M2X8	
5	140647101	1	电线固定夹	CORD HOLDER	
6	062400616	1	螺钉 M4X6	SCREW PAN M4X6	
7	062401216	1	螺钉 M4X12	SCREW PAN M4X12	
8	026040236	1	平垫圈 M4	WASHER PLAIN M 4	
9	154514001	1	衬垫	SPACER	
10	021400106	1	六角螺母 M4	NUT 1 M4	
11	SA4040001	1	手轮 CDD	PULLEY,CDD	
12	SA3175001	1	导向板	GUARD PLATE	
13	062300616	3	螺钉 M3X6	SCREW PAN M3X6	
14	028030246	3	弹簧垫圈 2-3	WASHER SPRING 2-3	
15	062060812	1	螺钉 M6X8	SCREW PAN M6X8	
16	025060136	1	平垫圈 S6	WASHER PLAIN S 6	
17	SA2712001	1	电线固定夹	CORD HOLDER	
18	062500816	1	螺钉 M5X8	SCREW PAN M5X8	
19	J80990001	1	马达组件 CDD-HT	MOTOR ASSY CDD-HT	
20	018501632	3	螺栓 M5X16	BOLT SOCKET M5X16	
21	028050247	3	弹簧垫圈 2-5	WASHER SPRING 2-5	
22	J03955001	1	磁鼓 CDD	DRUM CDD	
23	014400632	2	螺钉 M4X6	SET SCREW SOCKET (CP) M4X6	
24	J03956001	1	磁铁 180P36	MAGNET 180P36	
25	J03957001	1	MR感应器组件 180P	MR SENSOR ASSY 180P	
26	0A4301006	2	螺栓(带垫圈) M3X10DA	SCREW PAN (S/P WASHER) M3X10	
27	J03958001	1	屏蔽板 CDD	SHIELD PLATE CDD	
28	0A4261006	3	螺栓(带垫圈) M2.6X10DA	SCREW PAN (S/P WASHE) M2.6X10	
29	0A4401005	1	螺栓(带垫圈) M4X10DA	SCREW, PAN (S/P WASHE) M4X10	
30	J80971001	1	CDD-ENC基板组件#2	PCB ASSY CDD-ENC	
33	0A5300606	3	螺栓(带垫圈) M3X6DB	SCREW PAN (S/P WASHER) M3X6	
34	J04230001	1	电线固定夹 CDD-HT	CORD HOLDER CDD-HT	
35	0A4401006	2	螺栓(带垫圈) M4X10DA	SCREW PAN (S/P WASHE) M4X10	
36	J04296101	1	编码器盖 CDD#2	ENCODER COVER CDD #2	
37	0A4300806	3	螺栓(带垫圈) M3X8DA	SCREW PAN (S/P WASHER) M3X8	
38	J03964001	1	马达轮安装基座组件 CDD	PULLEY HOLDER ASSY CDD	
39	014500632	2	螺钉 M5X6	SET SCREW SOCKET (CP) M5X6	
40	SA2354001	5	螺钉 M5X18	SCREW PAN M5X18	
41	SA3025001	3	螺栓(带垫圈) M4X10DA	SCREW PAN(S/P WASHER)M4X10	
42	SA2687001	1	电线固定夹	CORD HOLDER	
43	062500816	1	螺钉 M5X8	SCREW PAN M5X8	
44	SA8530001	1	头部传感元件	HEAD DETECTOR UNIT	
45	062500816	2	螺钉 M5X8	SCREW PAN M5X8	
46	028050246	2	弹簧垫圈 2-5	WASHER SPRING 2-5	
47	026050136	2	平垫圈 S5	WASHER PLAIN S 5	
57	J04392001	1	LED 盖	LED COVER	
48	BMP2060-0000000-CG40		<用于中国> G40 操作盘(CH)	<For China Only> G-40-PANEL-CHINA	
48	BMP2060-0000000-0G40		<用于中国和欧洲以外> G40 操作盘	<Exept for China and Europe> G-40-PANEL	
48	BMP2060-0000000-EG40		<用于欧洲> G40 操作盘(EU)	<For Europe Only> G-40-PANEL-EU	
49	J80973001	1	G40操作盘基板组件	G40 PANEL PCB ASSY	
50	J80974001	1	G40副基板组件	G40 SUB PCB ASSY	
51	J03975001	1	G40操作盘面板 1	G40 PANEL SEAT 1	
52	J03976001	1	G40操作盘面板 2	G40 PANEL SEAT 2	
53	J04195001	1	操作盘安装架 #2	PANEL SETTING PLATE#2	
54	J04273001	3	螺栓(带垫圈) M4X10DB	SCREW, PAN(S/P WASHER)M4X10	
55	J03983001	3	霍尔元件 ICE W-400	HALL ELEMENT:ICE-400	
56	J03984001	2	霍尔元件 ICE W-450	HALL ELEMENT:ICE-450	

S2 . 控制箱装置 / Control box mechanism

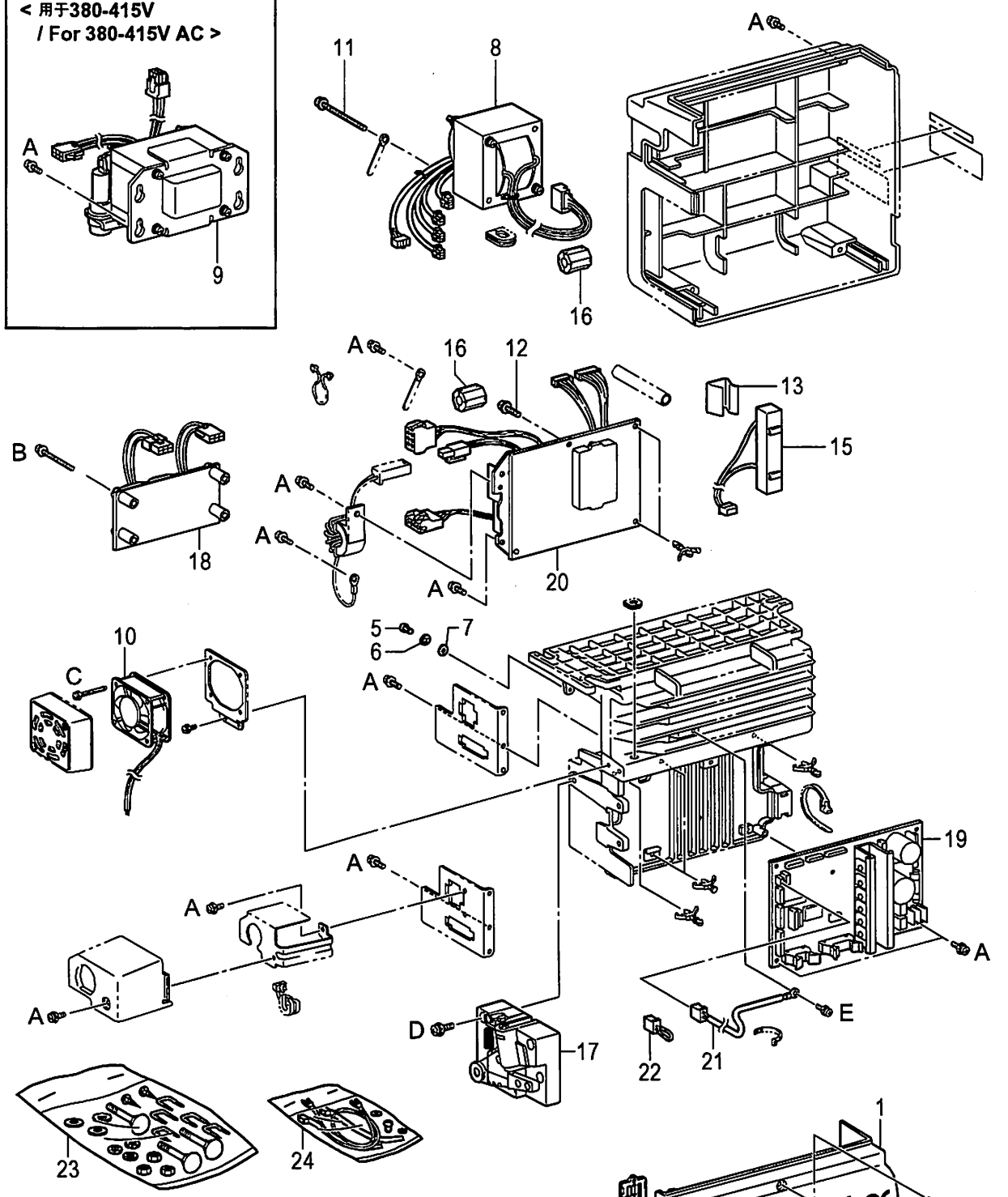
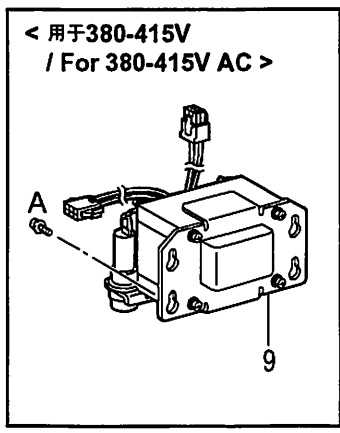

螺钉的种类 / Type of screw

A	4X10 DA
B	4X25 DA
C	4X35 DA
D	5X14 DB
E	3X8 DA

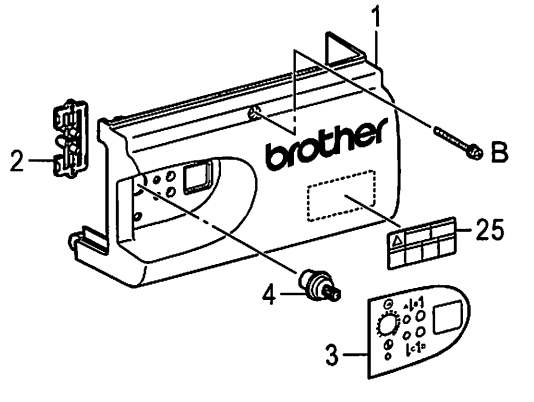

T-8722B-502

## S2 . 控制箱装置 / Control box mechanism

参照号	零部件序号	数量	零部件名称	NAME OF PARTS	RM
1	J04393001	1	前箱盖 CDD-GO	FRONT BOX COVER CDD GO	
2	J04438001	1	开关 CDD-GO	KEY TOP	
3	J04440001	1	面板 CDD-GO	PANEL SHEET CDD GO	
4	J04436001	1	微调旋钮	SPEED ADJUST KNOB	
5	062400863	1	螺钉 M4X8	SCREW PAN M4X8	
6	028040245	1	弹簧垫圈 2-4	WASHER SPRING 2-4	
7	025040173	1	平垫圈 S4	WASHER PLAIN S 4	
			<用于AC100 - 110V>	<For 100 - 110V AC>	
8	J04097001	1	变压器 CDD-100V	TRANSFORMER CDD-100V	
			<用于AC200 - 240V>	<For 200 - 240V AC>	
8	J04098001	1	变压器 CDD-200V	TRANSFORMER CDD-200V	
			<用于AC380 - 415V>	<For 380 - 415V AC>	
8	J04098001	1	变压器 CDD-200V	TRANSFORMER CDD-200V	
9	J04593001	1	变压器 400V-SP	TRANSFORMER 400V-SP	
10	J04167001	1	DC风扇CDD组件 #2	DC FAN ASSY, CDD #2	
11	J01411001	2	螺栓(带垫圈) M4X50DA	SCREW PAN (S/P WASHER) M4X50	
12	J00494001	2	螺栓(带垫圈) M4X14DA	SCREW PAN (S/P WASHER) M4X14	
13	J03739001	1	CR固定夹	SPRING PLATE, CR	
15	J04100001	1	电阻组件 R40/220#6	CEMENT RESISTOR ASSY 40/220 #6	
			<用于欧洲>	<For Europe>	
16	J04468001	2	衰减器 ESD-SR-120	CORE: SD-SR-120	
			<前和后各一档规格>	<Type forward 1 step, backward 1 step>	
17	J80967001	1	踏脚控制器CDD(日本国内)	TREADLE UNIT ASSY CDD G	
			<前和后各二档规格>	<Type forward 2 step, backward 2 step>	
17	J80968001	1	踏脚控制器CDD(出口用)	TREADLE UNIT ASSY CDD H	
			<用于欧洲>	<For Europe>	
18	J80970001	1	CE过滤基板组件	CE FILTER PCB ASSY	
19	J81008001	1	控制基板组件 CDD#GO-F	CONTROL PCB ASSY CDD #GO-F	
			<用于AC100 - 240V>	<For 100 - 240V AC>	
22	J04168001	1	短路插座	SHORT CONNECTOR	
			<用于AC380 - 415V>	<For 380 - 415V AC>	
21	J04169001	1	CDD热控管 #2	THERMISTOR, CDD #2	
			<用于AC100 - 110V>	<For 100 - 110V AC>	
20	J80965001	1	D基板组件 CDD1-110V	POWER PCB ASSY, CDD 1-110V	
			<用于AC220 - 415V>	<For 220 - 415V AC>	
20	J80966101	1	D基板组件 CDD1-230V	POWER PCB ASSY CDD 1-230V	
23	J04210001	1	螺钉一组 M8X65	BOLT ASSY, SQUARE M8X65	
24	J04243001	1	地线螺钉组件	EARTH CORD SCREW TIE ASSY	
25	J04115001	1	感电标签(6国)	LABEL, ELEC. SHOCK 6 LANG	

T. 倒缝开关装置 / Quick reverse switch mechanism

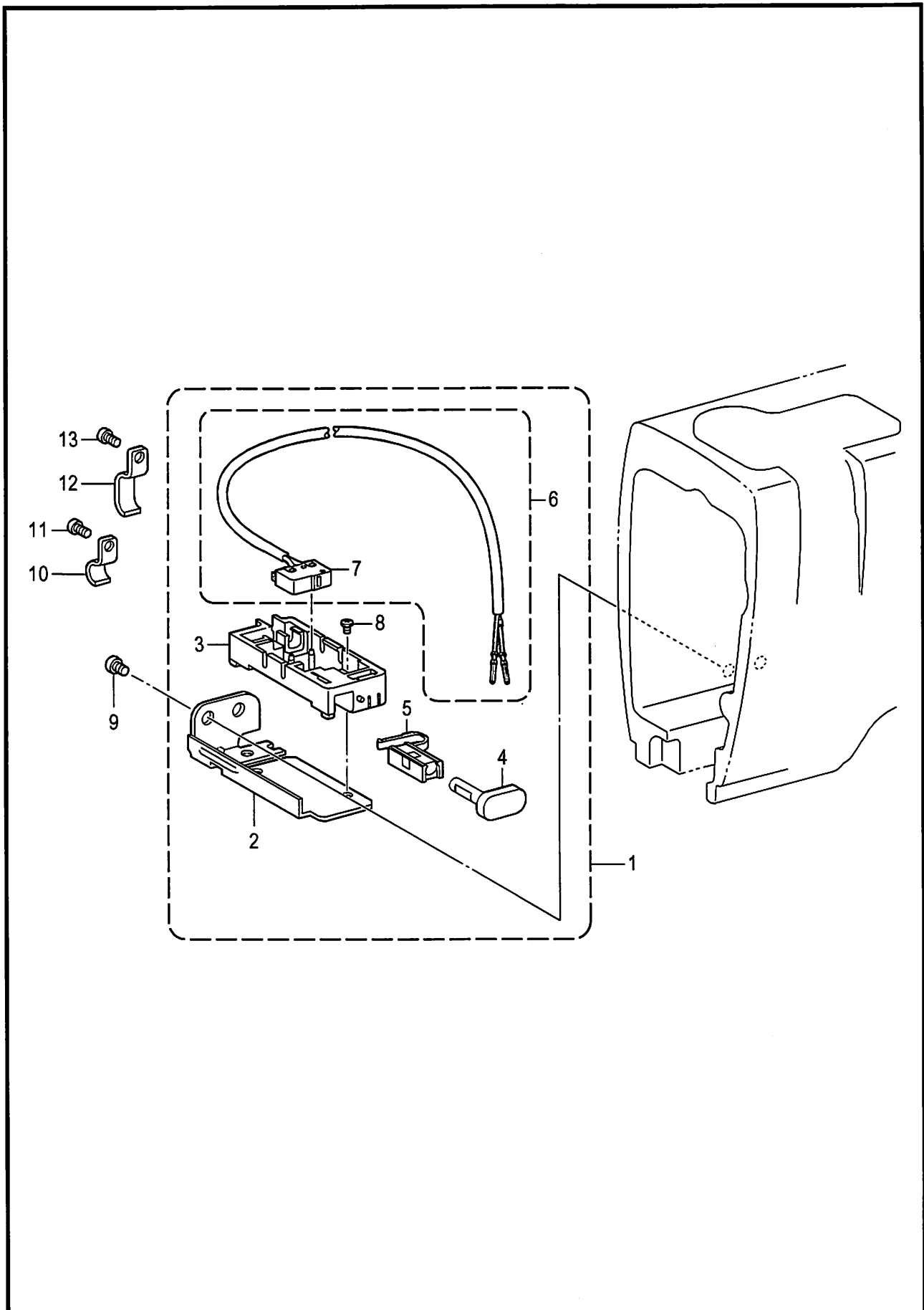

T-8722B-508



T. 倒缝开关装置 / Quick reverse switch mechanism

参照号	零部件序号	数量	零部件名称	NAME OF PARTS	RM
1	SA2688201	1	调节器按钮组件	REVERSE ACTUATOR ASSY	
2	SA2270001	1	倒缝开关安装架	REVERSE SWITCH BRACKET	
3	S34281000	1	倒缝开关基体	REVERSE SWITCH BRACKET	
4	SA4098101	1	按钮	ACTUATOR	
5	SA4099001	1	R-开关弹簧	REVERSE SWITCH SPRING	
6	SA1390001	1	R开关组件	R-SWITCH ASSY	
7	S32907050	1	微动开关	MICRO SWITCH	
8	060300606	1	螺钉 M3X6	SCREW BIND M3X6	
9	062500616	2	螺钉 M5X6	SCREW PAN M5X6	
10	SA2689101	1	线夹	CORD HOLDER	
11	062500616	1	螺钉 M5X6	SCREW PAN M5X6	
12	SA1388101	3	线夹	CORD HOLDER	
13	062500616	1	螺钉 M5X6	SCREW PAN M5X6	

T-8722B-508

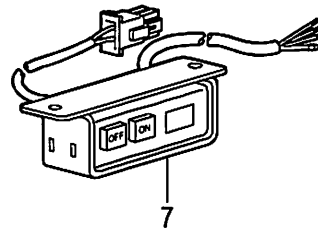
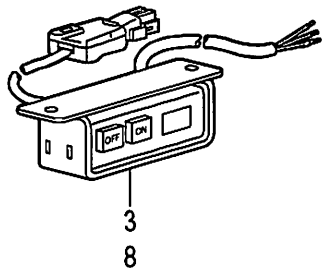
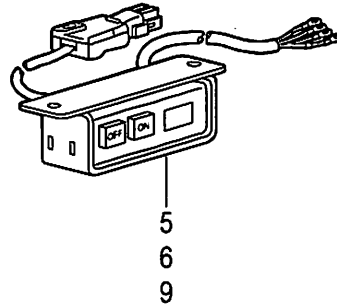
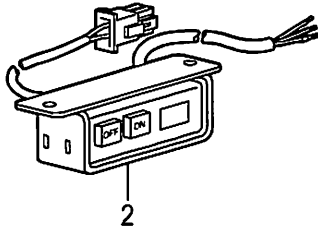
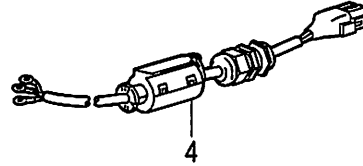
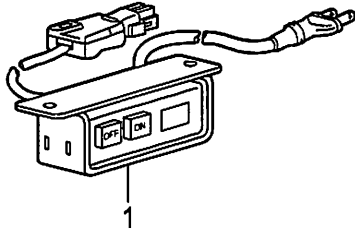

U. 电气部品装置 / Power supply equipment mechanism

参照号	零部件序号	数量	零部件名称	NAME OF PARTS	RM
1	J04086001	1	<用于单相 100V AC> <用于日本> 电源开关组件 1-100V#6	<For Single phase 100V AC> < For Japan > POWER SWITCH ASSY 1-100V #6	
2	J04469001	1	<用于单相 110V AC> <用于北美和墨西哥> 电源开关组件 1-110V#8	<For Single phase 110V AC> < For USA, Canada & Mexico > POWER SWITCH ASSY 1-110V #8	
3	J04093001	1	<用于单相 220V AC> <用于一般亚洲和北非> 电源开关组件 1-240V#6	<For Single phase 220V AC> < For General of Asia & North africa > POWER SWITCH ASSY 1-240V #6	
4	J04134001	1	<用于单相 230V AC CE > 无电源开关 <用于欧洲> 电源插头组件 1-240V#6	<For Single phase 230V AC CE> Power SW-less < For Europe > POWER PLUG ASSY 1-240V #6	
5	J04096001	1	<用于三相 380V AC > <用于一般亚洲和北非> 电源开关组件 3-400V#6	<For Three phase 380V AC> < For General of Asia & North africa > POWER SWITCH ASSY 3-400V #6	
6	J04149001	1	<用于三相 200V AC > <用于日本> 电源开关组件 3-200V#6	<For Three phase 200V AC> < For Japan > POWER SWITCH ASSY 3-200V #6	
7	J04470001	1	<用于三相 220V AC > <用于北美和墨西哥> 电源开关组件 3-240V#8	<For Three phase 220V AC> < For USA, Canada & Mexico > POWER SWITCH ASSY 3-240V #8	
8	J04251001	1	<用于单相 220V AC> <用于中国> 电源开关组件 1-240V#CCC	<For Single phase 220V AC> < For China > POWER SWITCH ASSY 1-240V #CCC	
9	J04255001	1	<用于三相 380V AC > <用于中国> 电源开关组件 3-400V#CCC	<For Three phase 380V AC> < For China > POWER SWITCH ASSY 3-400V #CCC	

T-8722B-515

V. 电磁抬压脚组件装置 (选购件) / Presser foot lifting solenoid set mechanism (Option parts)

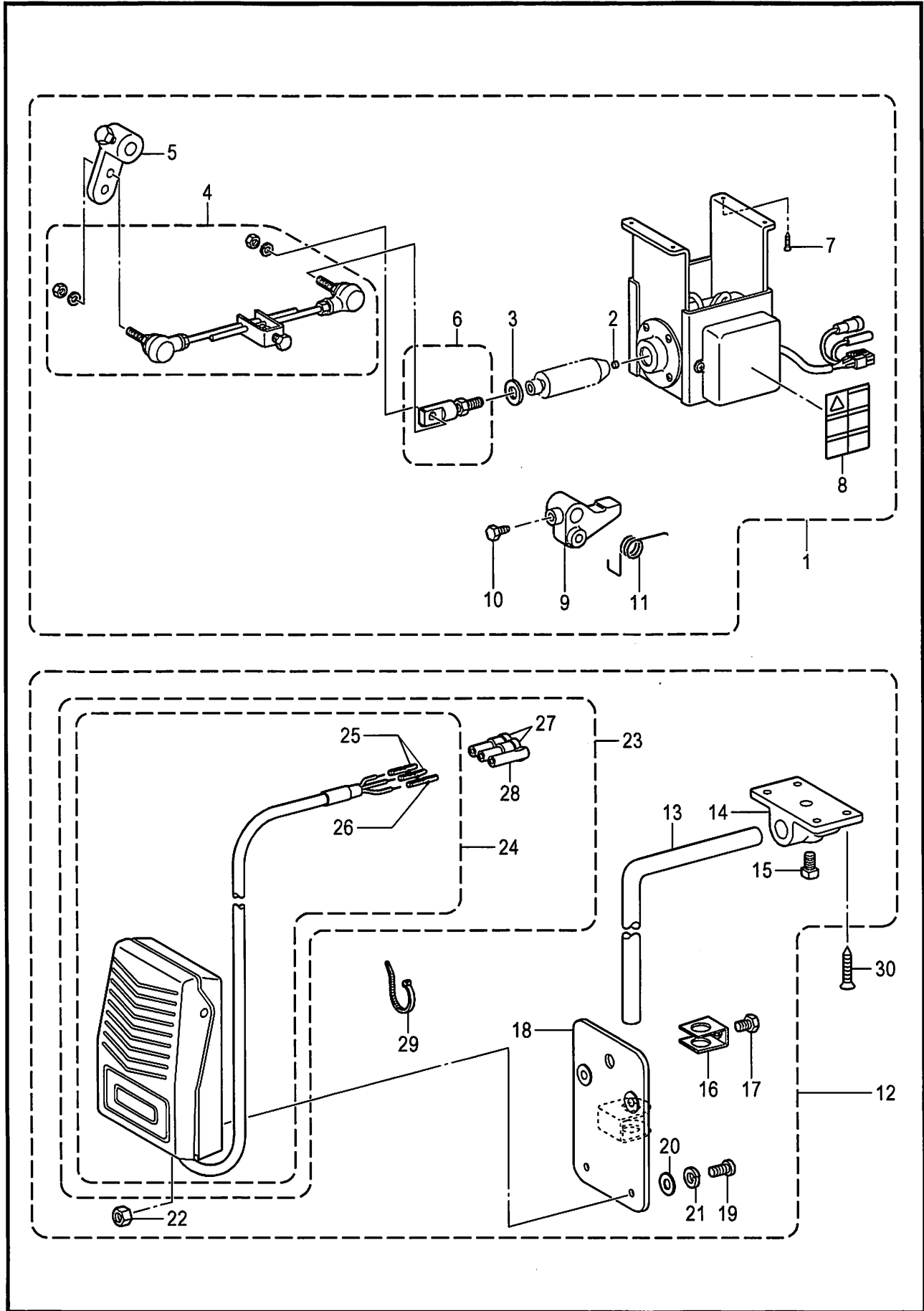

T-8722B-943

V. 电磁抬压脚组件装置(选购件)/ Presser foot lifting solenoid set mechanism (Option parts)

参照号	零部件序号	数量	零部件名称	NAME OF PARTS	RM
1	SA2707001	1	电磁抬压脚复合件 D2	P-FOOT LIFTER SOLENOID SET, D2	
2	S54025001	1	橡皮垫	CUSHION	
3	S54024001	1	橡皮垫圈	CUSHION RING	
4	S42198051	1	抬压脚杆组件	PRESSER FOOT LIFTER ROD ASSY	
5	S42199051	1	抬压脚手柄组件	P-FOOT LIFTER LEVER ASSY	
6	S41955051	1	连杆接头组件	ROD JOINT ASSY	
7	S42200051	4	木螺钉	WOOD SCREW	
8	S38351001	1	高温标志	LABEL, HIGH TEMP	
9	S10550001	1	抬压脚连杆	PRESSER BAR LIFTER LINK	
10	146367001	1	螺钉 SM5.95	BOLT, SM5.95	
11	S07729001	1	弹簧	SPRING, TWIST	
12	S07045009	1	膝控开关大组件	KNEE LIFTER SWITCH ASSY	
13	142026003	1	膝控开关弯杆	KNEE SWITCH SHAFT	
14	142027001	1	膝控开关弯杆座	BRACKET	
15	100463001	1	四角型螺拴 SM7.94	BOLT, SQUARE SM7.94	
16	114967001	1	碰块架	KNEE LIFTER PLATE STOPPER	
17	110087001	1	螺拴 SM5.95-28X8	BOLT, SM5.95-28X8	
18	S07027001	1	膝控开关按装板	K-LIFTER SWITCH SETTING PLATE	
19	062401006	4	螺钉 M4X10	SCREW PAN M4X10	
20	025040233	4	平垫圈 M4	WASHER, PLAIN M 4	
21	028040243	4	弹簧垫圈 2-4	WASHER, SPRING 2-4	
22	021400164	4	六角螺母 M4	NUT, 1 M4	
23	S07030009	1	膝控开关引线组件	SWITCH & HARNESS ASSY	
24	S07031009	1	膝控开关组件	FOOT SWITCH ASSY	
25	143549000	2	接头插针	TERMINAL PIN, MALE	
26	143548000	1	接头插芯	TERMINAL PIN, FEMALE	
27	146046000	2	尼龙接头	NYLON CONNECTOR	
28	146194000	1	尼龙接头	NYLON CONNECTOR	
29	149799000	1	塑料固定带 S	BEAD BAND, S	
30	034422503	4	十字平头木螺钉 M4.1X25	WOOD SCREW, FLAT 2 M4.1X25	

Z1 . 附件 / Accessories

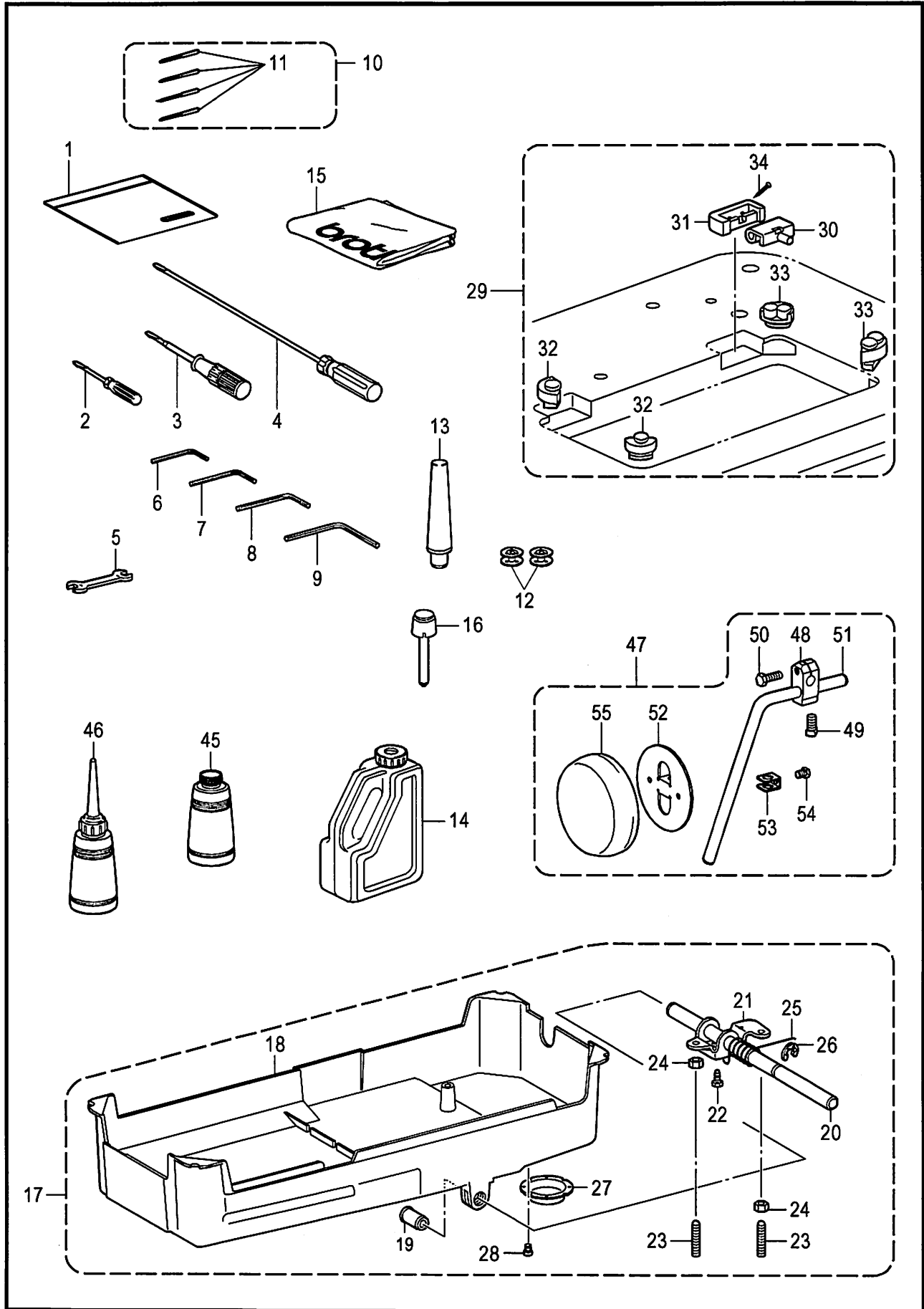

T-8722B-910

Z1 . 附件 / Accessories

参照号	零部件序号	数量	零部件名称	NAME OF PARTS	RM
1	122991001	1	附属品塑料袋	ACCESSORY BAG	
2	142443001	1	小起子 1.9X52	SCREW-DRIVER, 1.9X52	
3	118837001	1	起子 3.4X70	SCREW-DRIVER, 3.4X70	
4	S17774001	1	大起子 4.7X250	SCREW-DRIVER, 4.7X250	
5	100887001	1	双头扳手 8X9	WRENCH, 8X9	
6	142002001	1	内六角扳手 2	HEXAGONAL WRENCH, 2	
7	154125001	1	内六角扳手 2.5	HEXAGONAL WRENCH, 2.5	
8	142721001	1	内六角扳手 3	HEXAGONAL WRENCH, 3	
9	149570001	1	内六角扳手 5	HEXAGONAL WRENCH, 5	
			<用于-403>	<For -403>	
10	SA1752014	1	机针组 107415	NEEDLE 4PIECE ASSY, 107415	
11	107415014	4	机针 DPX5(#14)	NEEDLE, DPX5	
			<用于-405>	<For -405>	
10	SA1752022	1	机针组 107415	NEEDLE 4PIECE ASSY, 107415	
11	107415022	4	机针 DPX5(#22)	NEEDLE, DPX5	
12	S09285051	2	梭芯	BOBBIN	
13	100477009	1	机头撑杆	HEAD REST	
14	S55663001	1	油罐组件	OIL TANK ASSY	
15	144226001	1	机头罩	HEAD COVER	
16	145573000	1	膝控提升顶杆	KNEE LIFTER COMPLYING BAR	
17	SA2691101	1	油盘组件	OIL PAN ASSY	
18	SA2692101	1	油盘	OIL PAN	
19	149578000	2	轴套	BUSH	
20	SA2582001	1	膝控横轴	KNEE LIFTER SHAFT	
21	SA2590001	1	膝控	KNEE LIFTER	
22	S25344001	1	螺栓 M6	BOLT, M6	
23	S25475101	2	螺钉 M6X19	SET SCREW, M6X19	
24	021060306	2	六角螺母 M6	NUT, 3 M6	
25	S15889001	1	复位弹簧	TWIST SPRING	
26	146293001	1	挡圈 E10	RETAINING RING, E10	
27	153230101	1	放油口	DRAIN	
28	S23418002	2	螺钉 M4X5	SCREW, M4X5	
29	SA1969001	1	橡胶铰链组件	RUBBER HINGE ASSY	
30	143882001	2	机头铰链	HEAD HINGE	
31	143910009	2	机头铰链套	RUBBER CUSHION	
32	SA1962001	2	头部防震垫	HEAD CUSHION	
33	SA1963001	2	头部防震垫	HEAD CUSHION	
34	109714000	4	钉	NAIL	
45	114486002	1	油壶	OILER	
46	114483002	1	油壶组件	OILER ASSY	
47	S38300001	1	膝控组件	KNEE LIFTER ASSY	
48	146039121	1	碰块弯杆接头	KNEE LIFTER BRACKET	
49	100463021	1	四角型螺栓 SM7.94	BOLT, SQUARE SM7.94	
50	S35820021	1	螺栓 SM5.95X20	BOLT, SM5.95X20	
51	S38278001	1	膝控弯管	KNEE LIFTER BAR	
52	S34756021	1	膝控碰块	KNEE LIFTER PLATE	
53	114967021	1	碰块架	KNEE LIFTER PLATE STOPPER	
54	110087021	1	螺栓 SM5.95-28X8	BOLT, SM5.95-28X8	
55	S31885001	1	膝控碰块垫	KNEE LIFTER PLATE COVER	

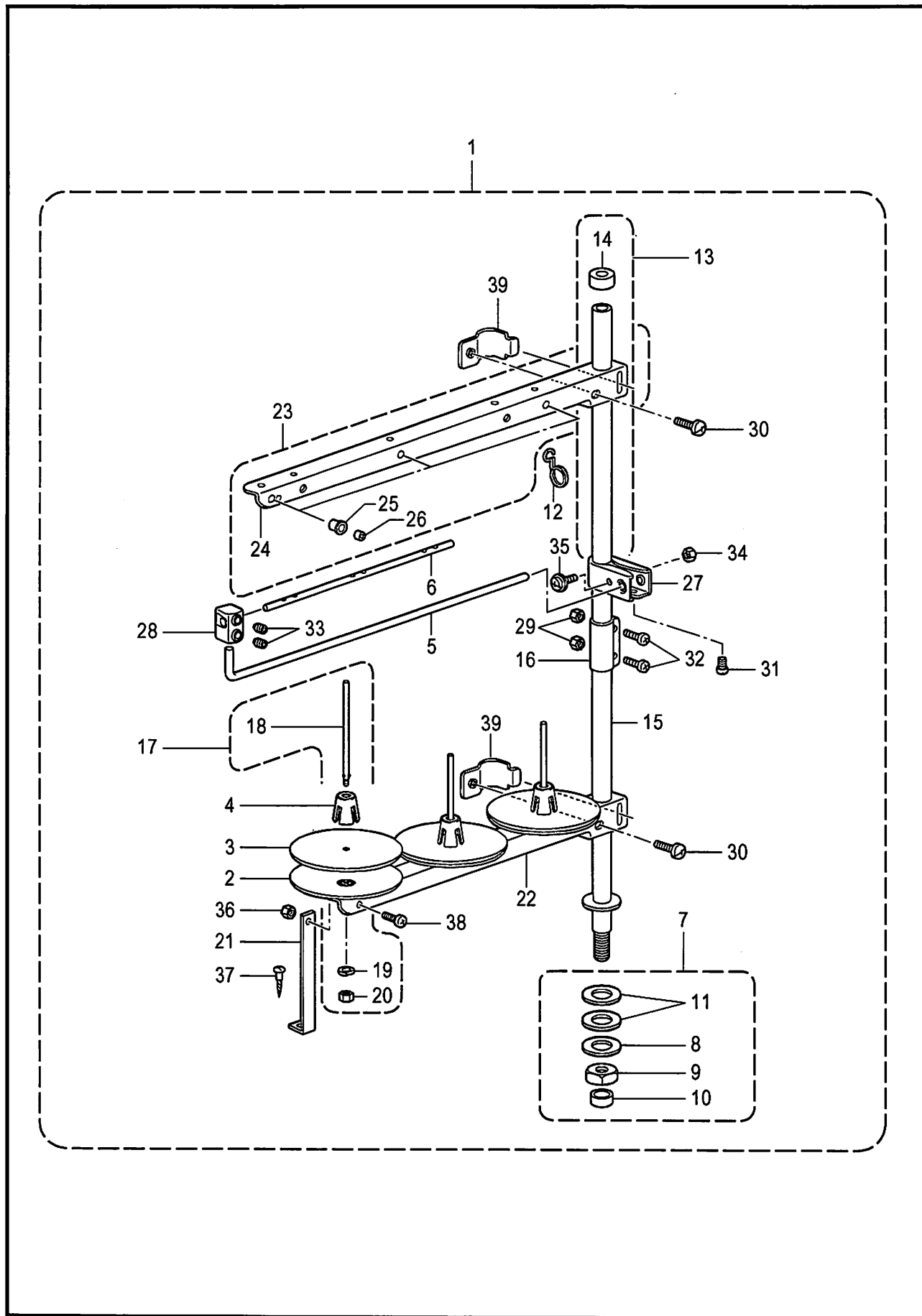



## Z2. 附件 / Accessories

参照号	零部件序号	数量	零部件名称	NAME OF PARTS	RM
1	S07558409	1	线架组件 3DRTHF	COTTON STAND ASSY 3DRTHF	
2	S51283001	3	垫圈	SPOOL STAND BASE	
3	150182000	3	线盘软垫	SPOOL MAT	
4	S51282101	3	线轴缓冲架	SPOOL CUSHION	
5	S04109001	1	过线杆支杆	THREAD GUIDE SUPPORT BAR	
6	142997001	1	过线杆 3	THREAD GUIDE, 3	
7	SA6627001	1	管D螺母组件 B	PIPE D SCREW SET B	
8	150206002	1	平垫圈 16	WASHER, PLAIN 16	
9	SA6629001	1	螺母 M16	NUT M16	
10	150174000	1	线架支撑管套	COLUMN CAP	
11	S01005000	2	橡皮垫圈	RUBBER WASHER	
12	S02747101	1	弹簧	SPRING	
13	S40639001	1	线架撑管带管套	COLUMN PIPE W/CAP	
14	150174000	1	线架支撑管套	COLUMN CAP	
15	156112003	1	线架撑管 D	COLUMN PIPE D	
16	SA6606001	1	线架管接头	COLUMN JOINT	
17	S21798001	3	线盘螺钉复合件	SPOOL & SCREW SET	
18	150179002	3	线轴 B	SPOOL SHAFT B	
19	028050244	3	弹簧垫圈 2-5	WASHER SPRING 2-5	
20	021500104	3	螺母 M5	NUT 1 M5	
21	150188009	1	下过线架支撑板 A	SPOOL HOLDER SUPPORT, A	
22	SA6610001	1	过线架 3	SPOOL HOLDER 3	
23	SA6611001	1	过线架组件 3	THREAD HANGER ASSY 3	
24	SA6610001	1	过线架 3	SPOOL HOLDER 3	
25	150183000	3	过线管套	THREAD HANGER BASE	
26	142990001	3	过线架上过线管	THREAD BUSH	
27	SA6615001	1	线导向架	THREAD GUIDE HOLDER	
28	138843001	1	连接器	JOINT	
29	021500104	2	螺母 M5	NUT 1 M5	
30	062061604	2	螺钉 M6X16	SCREW PAN M6X16	
31	S37037001	1	螺钉 M5X32	SCREW PAN (S/P WASHER) M5X32	
32	062501404	2	螺钉 M5X14	SCREW PAN M5X14	
33	014060632	2	固定螺钉 M6X6	SET SCREW SOCKET (CP) M6X6	
34	021500104	1	螺母 M5	NUT 1 M5	
35	S37037001	1	螺钉 M5X32	SCREW PAN (S/P WASHER) M5X32	
36	021500104	1	螺母 M5	NUT 1 M5	
37	031452204	1	圆头木螺钉 M4.5X22	WOOD SCREW ROUND M4.5X22	
38	062501004	1	螺钉 M5X10	SCREW PAN M5X10	
39	SA6609001	2	过线架定位	SPOOL HOLDER SUPPORTER	

T-8722B-910

Wa. 警告标签 / Warning labels

警告标签 / Warning labels	零部件名称 / Name of parts	尺寸 / Size(mm)	零部件序号 / Code
	<p>感电标签(6国) Label, elec. shock 6 lang</p>	<p>50 X 118</p>	<p>J04115-001</p>
	<p>操作注意标签 (日 / 英) Label, caution Jpn / Eng</p>	<p>64 X 40</p>	<p>SA2040-001</p>
	<p>操作注意标签 (中 / 英) Label, caution Chn / Eng</p>	<p>64 X 40</p>	<p>SA2041-001</p>
	<p>接地标记 Label, grounding</p>	<p>φ 12</p>	<p>S37060-001</p>
	<p>高温标志 Label, high temp</p>	<p>72 X 59</p>	<p>S38351-001</p>

T-8722B-Wa

## Sp. 不同规格零部件一览表 / Different parts list

### ■ 旋梭 / Rotary hooks

旋梭在下列选购件中列有，请选择符合自己所需要的使用。  
(零部件序号请使用旋梭放入旋梭盒内组件的零部件序号)

The following type of rotary hook are available. Select whichever one is suitable for your application.  
(The following parts codes are assigned for the rotary hooks in the boxes.)

#### ● 标准 / Normal

	全部规格 / All type
旋梭盒组件 / Rotary hook assy	SA1689-102
梭芯套组件 / Bobbin case assy	S09278-001

#### ● 选购件 / Option

##### ○ 旋梭尖的强化 / Rotary hook with reinforced hook point

强化旋梭的梭尖，是为了防止旋梭梭尖部的磨损。适用于在缝制不易形成线圈的布料  
(如有伸缩性的布料等)，旋梭梭尖部和机针有接触到似的情况下使用。

The rotary hook point is reinforced to improve its durability. This type is suitable for sewing materials that are hard to make loops on the surface ( like stretchy materials ), and that requires making contact with the hook point and the needles.

	全部规格 / All type
旋梭盒组件 / Rotary hook assy	SA1690-011
梭芯套组件 / Bobbin case assy	S09278-001

Ga . 工模具一览表 / Gauge parts list

**标准品 / For Normal**

- \* 切线用的定刀 (S07527-001) 和安装定刀用的螺钉 (148539-101) 没有附在针板上. 如需要的话. 请另行订货
- \* The thread trimming fixed knife (part No. S07527-001) and the installation screw (part No. 148539-101) are not provided with the needle plate, so they must be ordered separately if required.

针宽 Needle gauge	针夹组件 Needle clamp assy	针板 Needle plate	送布牙 Feed dog		压脚组件 Presser foot assy
		用于中厚, 厚布料 (-3,-5) For medium & heavy materials	用于中厚, 厚布料 (-3,-5) For medium & heavy materials	用于厚布料 (-5) For heavy materials	用于中厚, 厚布料 (-3,-5) For medium & heavy materials
3.2mm (1/8)	158794-101	155722-001	148698-001	148699-001	S36562-001
4.0mm (5/32)	158796-101	155724-001	148700-001	148701-001	155455-001
4.8mm (3/16)	158791-101	155851-001	148702-001	148703-001	S36564-001
6.4mm (1/4)	158792-101	155853-001	148704-001	148705-001	SA4052-101
7.9mm (5/16)	158793-101	155855-001	149692-001	149691-001	155459-001
9.5mm (3/8)	158798-101	155857-001	149939-001	149938-001	155461-001
12.7mm (1/2)	158797-101	149677-001	149676-001	149675-001	S09367-101
15.9mm (5/8)	158795-101	149954-001	149949-001	149948-001	159575-101
25.4mm (1)	158805-101	149966-001	S32054-001	149960-001	S13626-101
31.8mm (1 1/4)	158799-101	S10741-001		S10743-001	S10744-101
34.9mm (1 3/8)	S10746-101	S10748-001		S10750-001	S10751-101
38.1mm (1 1/2)	158800-101	S07391-001		S07390-001	156526-101

**用于有空缝时 / For sewing without material**

- \* 针板、送布牙和压脚组件均为非标准品. 请在最大节距为 4mm 以下时使用.
- \* Needle plate, the feed dog and presser foot assembly is different from normal parts.  
Use gauge components of for sewing without material which have a maximum feed pitch of 4mm or less.

针宽 Needle gauge	针夹组件 Needle clamp assy	针板 Needle plate	送布牙 Feed dog	压脚组件 Presser foot assy
4.8mm (3/16)	标准品 / Normal	S20901-001	S20905-001	S20903-001
6.4mm (1/4)		S10507-001	S10509-101	S10510-001
22.2mm (7/8)		S14538-001	S14540-101	S14541-101
25.4mm (1)		S14543-001	S14545-001	S14546-101

**用于厚布料 / For heavy materials**

- \* 送布牙为非标准品.
- \* The feed dog is different from normal parts.

针宽 Needle gauge	针夹组件 Needle clamp assy	针板 Needle plate	送布牙 Feed dog	压脚组件 Presser foot assy
4.8mm (3/16)	标准品 / Normal	标准品 / Normal	S07905-001	标准品 / Normal
6.4mm (1/4)			158756-001	

**标准品 / For Normal**

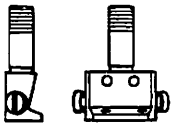
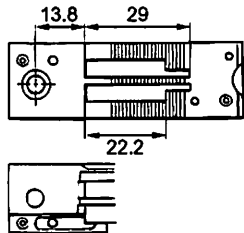
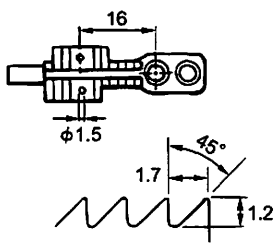
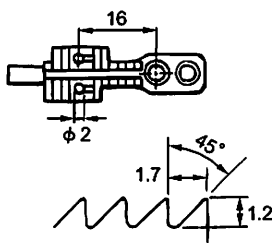
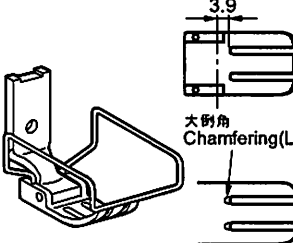
<p>针夹组件 Needle clamp assy</p>	<p>针板 Needle plate</p> <p>用于中厚、厚布料 (-3,-5) For medium &amp; heavy materials</p>	
		
<p>送布牙 Feed dog</p>		
<p>用于中厚布料 (-3) For medium materials</p>	<p>用于厚布料 (-5) For heavy materials</p>	<p>压脚组件 Presser foot assy</p> <p>用于中厚、厚布料 (-3,-5) For medium &amp; heavy materials</p>
		

**用于有空缝时 / For sewing without material**

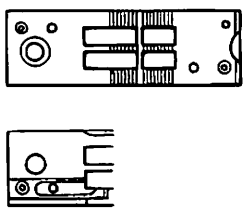
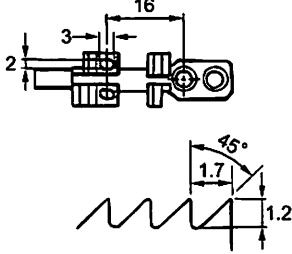
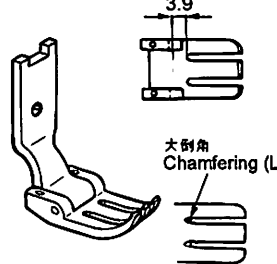
<p>针板 Needle plate</p>	<p>送布牙 Feed dog</p>	<p>压脚组件 Presser foot assy</p>
		

**用于厚布料 / For heavy materials**

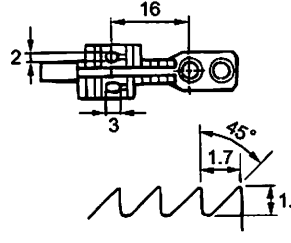
<p>送布牙 Feed dog</p>









CODE	REF.NO	Page	CODE	REF.NO	Page	CODE	REF.NO	Page	CODE	REF.NO	Page
SA2802501	J1 - 42	18	SA3990001	G - 19	14	SA6610001	Z2 - 24	52			
SA2806001	G - 30	14	SA4007001	C - 15	6	SA6611001	Z2 - 23	52			
SA2824001	M - 20	30	SA4009001	G - 32	14	SA6615001	Z2 - 27	52			
SA2826001	J1 - 41	20	SA4011001	G - 35	14	SA6627001	Z2 - 7	52			
SA2860001	P - 16	34	SA4012001	J1 - 29	18	SA6629001	Z2 - 9	52			
SA2861101	B - 23	4		J1 - 29	20	SA7540001	L - 24	26			
SA2927001	G - 12	14	SA4026001	J1 - 13	18	SA7548001	L - 31	26			
SA2928001	G - 28	14	SA4028001	G - 3	14	SA7607001	D - 5	8			
SA2929001	A - 4	2	SA4033101	L - 13	26	SA7868001	J1 - 63	18			
	A - 23	2	SA4038001	J1 - 4	18		J1 - 63	20			
	A - 24	2	SA4040001	S1 - 11	40	SA8012001	J1 - 22	18			
	L - 10	26	SA4044001	J1 - 27	18		J1 - 22	20			
	L - 18	26	SA4045001	J1 - 46	20	SA8364001	P - 61	34			
SA2937101	B - 22	4	SA4052101	Ga	55	SA8365001	P - 62	34			
SA2956001	L - 5	26	SA4089001	B - 2	4	SA8530001	S1 - 44	40			
SA2957001	L - 6	26	SA4098101	T - 4	44	SA8745001	R - 22	38			
SA2992001	F - 8	12	SA4099001	T - 5	44						
	F - 14	12	SA4117001	C - 30	6						
SA3025001	S1 - 41	40	SA4118001	C - 32	6						
SA3040001	L - 2	26	SA4124301	C - 1	6						
	L - 32	26	SA4149101	D - 34	8						
SA3044001	L - 39	26	SA4205101	L - 1	26						
SA3045201	L - 36	26	SA4212001	M - 3	30						
SA3046001	L - 37	26	SA4213001	K - 15	24						
SA3048101	L - 51	26	SA4215101	L - 12	26						
SA3049001	L - 52	26	SA4444001	J1 - 4	18						
SA3054001	J1 - 24	18	SA4506001	M - 34	30						
SA3055101	L - 7	26	SA4507001	M - 35	30						
	L - 40	26	SA4537001	B - 28	4						
SA3056001	E - 20	10	SA4538001	G - 29	14						
SA3058101	B - 29	4	SA4585001	K - 2	24						
SA3059101	B - 31	4		K - 4	24						
SA3060001	L - 33	26	SA5026101	L - 3	26						
SA3062001	E - 1	10	SA6150101	G - 11	14						
SA3065001	B - 30	4	SA6166001	B - 5	4						
SA3072001	F - 1	12	SA6178001	L - 8	26						
SA3175001	S1 - 12	40	SA6294101	J1 - 62	18						
SA3415001	M - 2	30		J1 - 62	20						
SA3416101	M - 2	30	SA6308001	G - 31	14						
SA3417301	M - 1	30	SA6378001	M - 46	30						
SA3710001	C - 6	6	SA6392001	P - 23	34						
SA3711101	C - 9	6	SA6393001	P - 24	34						
SA3712001	C - 10	6	SA6394001	P - 25	34						
SA3840001	G - 10	14	SA6395001	P - 17	34						
SA3848001	C - 17	6	SA6414001	L - 61	28						
SA3852001	C - 19	6	SA6415001	L - 29	26						
SA3854001	C - 2	6	SA6416001	L - 60	28						
SA3855001	G - 1	14	SA6417001	J1 - 50	20						
SA3857001	J1 - 8	18	SA6423001	L - 28	26						
SA3861001	J1 - 9	18		L - 59	28						
SA3887001	G - 20	14	SA6424101	J1 - 25	18						
SA3888001	G - 21	14	SA6425101	J1 - 45	20						
SA3889101	J1 - 12	18	SA6462001	J1 - 48	20						
SA3890001	K - 1	24	SA6463001	J1 - 49	20						
SA3891001	K - 3	24	SA6468001	L - 27	26						
SA3894001	J1 - 30	18	SA6472001	L - 41	26						
	J1 - 30	20	SA6473001	L - 54	26						
SA3912001	J1 - 36	18	SA6474001	J1 - 7	18						
	J1 - 36	20	SA6475001	L - 25	26						
SA3923101	L - 42	26	SA6592001	E - 41	10						
SA3924001	A - 2	2	SA6606001	Z2 - 16	52						
SA3946001	L - 4	26	SA6609001	Z2 - 39	52						
SA3965001	G - 2	14	SA6610001	Z2 - 22	52						

**brother.**<sup>®</sup>

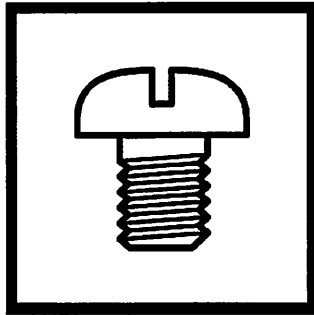

零件手册  
PARTS BOOK

兄弟工业株式会社 <http://www.brother.com/>

日本国，名古屋市瑞穂区苗代町15番1号 邮编：467-8561 电话：81-52-824-2177

**BROTHER INDUSTRIES, LTD.** <http://www.brother.com/>

15-1, Naeshiro-cho, Mizuho-ku, Nagoya 467-8561, Japan. Phone : 81-52-824-2177

---

T-8722B  
SA4170-101  
2006.11.B (1)